

ELECTRICUB™

INSTRUCTION MANUAL

IMPROVED



WARRANTY

Great Planes Model Manufacturing Co. guarantees this kit to be free from defects in both material and workmanship at the date of purchase. This warranty does not cover any component parts damaged by use or modification. **In no case shall Great Planes' liability exceed the original cost of the purchased kit.** Further, Great Planes reserves the right to change or modify this warranty without notice.

In that Great Planes has no control over the final assembly or material used for final assembly, no liability shall be assumed nor accepted for any damage resulting from the use by the user of the final user-assembled product. By the act of using the user-assembled product, the user accepts all resulting liability.

If the buyers are not prepared to accept the liability associated with the use of this product, they are advised to return this kit immediately in new and unused condition to the place of purchase.

READ THROUGH THIS INSTRUCTION MANUAL FIRST. IT CONTAINS IMPORTANT INSTRUCTIONS AND WARNINGS CONCERNING THE ASSEMBLY AND USE OF THIS MODEL.



P.O. Box 788 Urbana, IL 61801 (217) 398-8970
productsupport@greatplanes.com

TABLE OF CONTENTS

SAFETY PRECAUTIONS	2
INTRODUCTION	3
IF YOU'RE NEW TO ELECTRICS	3
Keep it Light	3
DECISIONS YOU MUST MAKE	3
Radio Selection	3
Motor Selection	4
Battery Selection	4
Chargers	4
PREPARATIONS	4
Required Accessories	4
Power Supplies	5
Building System	5
Tools	5
Optional Supplies & Tools	5
Common Abbreviations	6
Types of Wood	6
Metric Conversions	6
Important Building Notes	6
Die Patterns	7
BUILD THE TAIL SURFACES	8
Build the Fin and Rudder	8
Build the Stabilizer and Elevator	8
Finish the Tail Surfaces	11
BUILD THE WING	11
Build the Wing Panels	11
Join the Wing Panels	14
Assemble and Install the Wing Tips	15
Build the Ailerons	16
Finish the Wing	18
BUILD THE FUSELAGE	19
Assemble the Fuselage Sides	19
Join the Fuselage Sides	21
Sand the Fuselage	27
Mount the Wing	28
Mount the Stabilizer and Fin	29
Install the Dowel Stringers	30
Mount the Landing Gear	31
Build the Motor Mount	32
Mount the Cowl	33
Construct the Wing Struts	34
RADIO INSTALLATION	34
Mount the Servos	34
Install the Nylon Control Horns	35
Make the Pushrods	35
BALANCE THE AIRPLANE Laterally	37
FINISHING	37
Final Sanding	37
Covering the Model	37
Painting Your Model	38
FINAL HOOKUPS AND CHECKS	39
Install the Hinges	39
Install the Wheels	40
Install the Plastic Parts	40
Install the Motor Battery	41
Reinstall the Radio System	41
BALANCE YOUR MODEL	42

FINISH THE RADIO INSTALLATION	43
INSTALL THE WING STRUTS	43
SET THE CONTROL THROWS	44
PROPER CARE OF YOUR MOTOR	44
PERFORMANCE TIPS	45
PREFLIGHT	45
Charge the Radio Batteries	45
Balance the Propeller	45
Find a Safe Place to Fly	46
Ground Check the Model	46
Range Check Your Radio	46
AMA SAFETY CODE	46
General	46
Radio Control	46
FLYING	46
Takeoff	47
Flight	47
Landing	47
2-VIEW DRAWING	back cover

**PROTECT YOUR MODEL, YOURSELF
& OTHERS...FOLLOW THESE
IMPORTANT SAFETY PRECAUTIONS**

Your **ElectriCub** is not a toy, but rather a sophisticated, working model that functions very much like an actual airplane. Because of its realistic performance, the **ElectriCub**, if not assembled and operated correctly, could possibly cause injury to yourself or spectators and damage property.

To make your R/C modeling experience totally enjoyable, we recommend that you get experienced, knowledgeable help with assembly and during your first flights. You'll learn faster and avoid risking your model before you're truly ready to solo. Your local hobby shop has information about flying clubs in your area whose membership includes qualified instructors.

You can also contact the national Academy of Model Aeronautics (AMA), which has more than 2,500 chartered clubs across the country. Through any one of them, instructor training programs and insured newcomer training are available. Contact the AMA at the address or toll-free phone number below.



Academy of Model Aeronautics
5151 East Memorial Drive
Muncie, IN 47302-9252
Tele. (800) 435-9262
Fax (765) 741-0057

or via the Internet at <http://www.modelaircraft.org>

SAFETY PRECAUTIONS

1. Build the plane according to the plan and instructions. Do not alter or modify the model, as doing so may result in an unsafe or unflyable model. In a few cases the plan and instructions may differ slightly from the photos. In those instances the plan and written instructions are correct.
2. Take time to build straight, true and strong.
3. Use an R/C radio system that is in first-class condition, and a correctly sized motor and components (batteries, wheels, etc.) throughout your building process.
4. You must properly install all components so that the model operates properly on the ground and in the air.
5. You must check the operation of the model before **every** flight to ensure that all equipment is operating and that the model has remained structurally sound. Be sure to check nylon clevises or other connectors often and replace them if they show signs of wear or fatigue.

NOTE: We, as the kit manufacturer, provide you with a top quality kit and great instructions, but ultimately the quality of your finished model depends on how **you** build it; therefore, we cannot in any way guarantee the performance of your completed model, and no representations are expressed or implied as to the performance or safety of your completed model.

Remember: Take your time and follow directions to end up with a well-built model that is straight and true.

Please inspect all parts carefully before starting to build! If any parts are missing, broken or defective, or if you have any questions about building or flying this airplane, please call us at:

(217) 398-8970
or e-mail us at:
productsupport@greatplanes.com.

If you are calling for replacement parts, please reference the part numbers and the kit identification number (stamped on the end of the carton) and have them ready when calling.

INTRODUCTION

Since the original ElectriCub was introduced in 1987, electric airplanes have grown in popularity and so has the technology. Over the years modelers have told us what they would like to see different on the ElectriCub. We've been listening! The redesigned ElectriCub now comes with ailerons, clear windows and is designed for mini servos. We've done extensive testing of motors, gearboxes and props to find the best combination, at the lowest price, for the new ElectriCub.

While the ElectriCub is easy to fly, it does not have the total self-recovery and stability of a basic trainer like the Great Planes series of PT basic trainers. Therefore, if you have never flown an R/C airplane before, we strongly recommend that you seek out the assistance of an experienced R/C pilot who will be able to check out your construction and help you with your first flights. We do know that once you have flown the ElectriCub you will want to keep it in your vehicle for that quick flight during your lunch break or to relax with a few flights after work.

IF YOU'RE NEW TO ELECTRICS

Keep It Light

Because the electric motor and motor battery are relatively heavier than a glow engine, it is essential that the basic structure of the airplane be kept as light as possible. In doing so, you will help insure that the finished airplane will not be too heavy to fly well.

One way to prevent excess weight build-up is to use only as much glue as needed for a good glue joint. Do not apply extra "fillets" of glue thinking that it will make your plane stronger! Extra glue could possibly add ounces to the weight of your plane and detract from the performance.

We will give you tips throughout this book on how to keep the structure light and we urge you to follow them.

DECISIONS YOU MUST MAKE

Radio Selection

Because weight is an important factor in the ElectriCub, the ideal radio system is one that has a miniature receiver, three mini servos such as Futaba®'s S3101 servos and an electronic speed control with BEC (Battery Eliminator Circuitry such as the Great Planes Speed 300 GPMM2030). The electronic speed control with BEC uses the motor battery, not a separate receiver battery, to power the receiver and servos. When the motor battery voltage reaches a preset voltage, the BEC on the speed control stops the motor while still supplying power to the receiver and servos. This setup can reduce the weight of the plane by as much as 4 oz. However, the ElectriCub will fly great with four mini servos, a 270 mAh receiver battery and a micro switch. This setup is a great, inexpensive way for the first-time **electric** pilot to try electric flight. Once you're hooked on the clean and quiet advantages of electric flight, you can replace the micro switch with a high quality electronic speed control.

Motor Selection

In testing the ElectriCub, many different motors were evaluated. Some of them provided adequate thrust to fly the ElectriCub satisfactorily. Some, however, gave such marginal performance that the climb-out was very shallow and flight times were short. Generally, a high performance, high power motor, like the Great Planes S-600™ direct drive motor, will give the ElectriCub a good climb rate and good aerobatic capability, but will result in a relatively short run time of 3 to 4 minutes.

The Great Planes T600r™ reverse rotation motor with a 2.5:1 gear drive unit enables the motor to turn a larger, more efficient propeller at a slower speed. This usually results in more thrust for a better climb rate and longer flight times up to 8 minutes. We consider this motor and gear drive combination (GPMG0760) to be the system of choice for the ElectriCub. See "Power Systems" on page 5.

Battery Selection

The ElectriCub was designed to fly on a 7-cell 8.4 volt 1700 - 2000 mAh flat battery pack. Even though the ElectriCub will fly well on an inexpensive motor battery pack, we recommend a battery pack that uses Sanyo® or Panasonic® cells. These cells have a low internal resistance which translates into more power and less heat.

If you are new to electric airplanes (or even cars and boats) here is a short explanation of NiCd batteries. A single cell NiCd battery supplies 1.2 volts with no load (not powering anything). A 7- cell battery pack can supply 8.4 volts (1.2 volts x 7 cells = 8.4 volts). The cell rating in mAh (milli-amp-hours) is the amount of current the battery can supply. If a battery is rated at 1700 mAh, the battery can supply 1.7 amps for 1 hour (or 1 amp for 1.7 hours). This sounds great – flying for over 1-1/2 hours on a single battery charge! The bad news is that to produce the power needed to fly an airplane the size of the ElectriCub, the motor draws from 15-25 amps. The current consumption reduces the run time to 4-6 minutes. The good news is that propellers become more efficient as the speed of the plane increases. This lowers the current draw, allowing the plane to fly longer on a single charge, sometimes up to 20% longer. Also, if an electronic speed control is used, the motor can be throttled back, increasing the flight time. Most airplanes only need full throttle during takeoff.

We recommend the use of high quality battery packs. The higher quality batteries usually have less internal resistance than the average battery. The higher quality battery will provide more power to the motor than the average battery. In NiCd batteries, internal resistance transforms power into heat. With less internal resistance, there is more power available to the motor and less heat is generated. We hope this helps explain NiCd batteries and why a high quality battery should be used in the ElectriCub.

Chargers

A fully charged battery pack will provide an initial "surge" of power during the first 15 to 30 seconds of the motor run. Then the power output stays fairly steady for the next several minutes before dropping off quickly. If you do not charge your battery completely, it will not deliver that surge necessary for a good takeoff and climb out. There are three easy ways to "peak-charge" your battery pack.

1. The easiest way is with a "peak-detecting" battery charger. This type of charger will automatically charge your battery until it is fully charged.
2. The second method of charging your motor batteries is to monitor the voltage of your battery pack with a voltmeter. Your charger may have sockets into which you may plug a voltmeter. If not, you may insert the probes from the voltmeter into the rear of the battery plug, making contact with the metal contacts. As your battery charges, the voltage will gradually increase. When the battery is fully charged, the voltage will start to **drop**. At this point your battery is fully charged.
3. The third (and least reliable) method of "peak-charging" your battery pack is by checking its temperature. As the battery charges it will remain cool until it is fully charged. When it reaches the fully charged state, it will rapidly build up heat. You can feel this heat with your hand. As soon as the pack starts to noticeably warm up, disconnect it from the charger. **Do not continue charging if the battery pack is hot!** Overcharging will damage your battery pack and can result in an explosion.

PREPARATIONS

Required Accessories

Items in parentheses (GPMQ4243) are suggested part numbers recognized by most distributors and hobby shops and are listed for your ordering convenience. GPM is the Great Planes brand, TOP is the Top Flite® brand, HCA is the Hobbico® brand and COV is the Coverite™ brand.

- 4 Channel radio with 4 mini servos
- (2) 2" Ultralight Wheels (GPMQ4201)
- (1) 3/4" Tail wheel (GPMQ4240)
- (4) 1/8" Wheel collars (GPMQ4304)
- (1) 1/16" Wheel collar (GPMQ4300)
- (1 Roll) Double-Sided Foam Tape (GPMQ4440)
- (1) 1/6 Scale Pilot
- (2) Rolls covering film
- Motor battery pack charger 900 AC/DC Charger (HCAP0125) or 925 AC/DC Peak Detection Charger (HCAP0198)
- 1700mAh 8.4 volt NiCd battery pack (DTXC2071) or 2000mAh 8.4 volt NiCd battery pack (DTXC2076)

Power Systems

Good: GPMG0755 S-600 Motor System

S-600 motor (GPMG0710)
8 x 4 propeller
Propeller adapter
Wiring harness with fuse and micro switch

Better: GPMG0760 T600GD System with Gear Drive

T600R reverse rotation motor (GPMG0700)
2.5:1 gearbox (GPMG0850)
Propeller adapter (GPMG0855)
10 x 8 propeller for electrics
Wiring harness with fuse and micro switch

Best: GPMG0760 T600GD ESC System with Gear Drive and electronic speed control

T600r reverse rotation motor (GPMG0700)
2.5:1 gearbox (GPMG0850)
Propeller adapter (GPMG0855)
10 x 8 propeller for electrics
Speed 300 Electronic speed control with BEC and auto cutoff (GPMM2030)

Building Supplies

These are the building supplies that are required. We recommended **Great Planes Pro™ CA and Epoxy glue.**

- 1 oz. Thin Pro™ CA (GPMR6002)
- 1 oz. Medium Pro CA (GPMR6008)
- 6-Minute Pro Epoxy (GPMR6045)
- 30-Minute Pro Epoxy (GPMR6047)
- Thread locking compound (GPMR6060)
- Balsa filler (HCAR3401)
- Plan protector (GPMR6167)
- Isopropyl rubbing alcohol (70%)
- Paper towels

Tools

- Sanding block and sandpaper (coarse, medium, fine)
- Hobby knife (HCAR0105)
- #11 blades (HCAR0211)
- Single-edge razor blades (HCAR0212)
- Razor saw
- Razor plane (MASR1510)
- Electric drill
- Drill bits - 1/16", 3/32", 7/64", 1/8", 5/32", 11/64", 3/16"
- Small Phillips and flat blade screwdrivers
- Pliers with wire cutter (HCAR0630)
- Sealing iron (TOPR2100)
- Heat gun (TOPR2000)
- T-Pins (HCAR5150)
- Straightedge with scale (HCAR0475)
- Cutting mat (HCAR0456)
- Builder's triangle (HCAR0480)

- 10-24 Tap and Drill set
- Masking tape (TOPR8018)
- Panel line pen (TOPQ2510)

Optional Supplies and Tools

- CG Machine™ (GPMR2400)
- Accu Throw™ Deflection Meter (GPMR2405)
- CA Applicator tips (HCAR3780)
- CA Debonder (GPMR6039)
- Clevis installation tool (GPMR8030)
- Hot Sock™ (TOPR2175)
- Curved-tip canopy scissors (HCAR0667)
- Top Flite Precision Magnetic Prop Balancer™ (TOPQ5700)
- Slot Machine™ motorized hinge slotting tool (GPMR4010)
- Precision hinge marking tool (GPMR4005)
- Groove tube (GPMR8140)



On our workbench, we have three 11" **Great Planes Easy-Touch™ Bar Sanders**, equipped with #80, #150 and #220-grit sandpaper. This setup is all that is required for almost any sanding task. We also keep some #320-grit wet-or-dry sandpaper handy for finish sanding before covering.



Great Planes **Easy-Touch Bar Sanders** are made from lightweight extruded aluminum and can be found at most hobby shops. They are available in five sizes.

5-1/2" (GPMR6169) for those tight, hard-to-reach spots; 11" (GPMR6170) for most general purpose sanding; 22" (GPMR6172), 33" (GPMR6174) and 44" (GPMR6176) for long surfaces such as wing leading edges. The **Easy-Touch Adhesive-Backed Sandpaper** comes in 2" x 12' rolls of 80-grit (GPMR6180), 150-grit (GPMR6183) and 220-grit (GPMR6185) and an assortment of 5-1/2" long strips (GPMR6189) for the short bar sander. The adhesive-backed sandpaper is easy to apply and remove from your sanding bar when it's time for replacement.

Custom sanding blocks can be made from balsa or hardwood blocks and dowels for sanding difficult-to-reach spots.

Common Abbreviations

Elev = Elevator	Fuse = Fuselage
LE = Leading Edge (front)	LG = Landing Gear
Lt = Left	Ply = Plywood
Rt = Right	Stab = Stabilizer
TE = Trailing Edge (rear)	" = Inches

Types of Wood

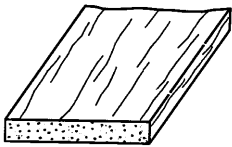

Balsa

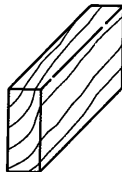

Basswood

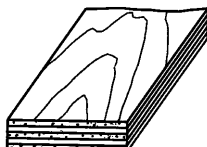

Plywood

Metric Conversions

1" = 25.4mm (conversion factor)

1/64" = .4mm	1" = 25.4mm
1/32" = .8mm	2" = 50.8mm
1/16" = 1.6mm	3" = 76.2mm
3/32" = 2.4mm	6" = 152.4mm
1/8" = 3.2mm	12" = 304.8mm
5/32" = 4mm	15" = 381mm
3/16" = 4.8mm	18" = 457.2mm
1/4" = 6.4mm	21" = 533.4mm
3/8" = 9.5mm	24" = 609.6mm
1/2" = 12.7mm	30" = 762mm
5/8" = 15.9mm	36" = 914.4mm
3/4" = 19mm	

IMPORTANT BUILDING NOTES

1. Unroll the plan sheets, then reroll the plan inside-out to make them lie flat.
2. Sort through the sticks and sheets, grouping them by size. Masking tape can be used to bundle matching sheets and sticks. Using a felt tip or ballpoint pen, lightly write the part **name** or **size** on each piece or bundle. Refer to the parts list and plan for sizes and quantities. Use the die-cut patterns shown on page 7 to identify the die-cut parts and mark them **before** removing them from the die sheet. Save all leftovers. If any of the die-cut parts are difficult to remove, do not force them! Instead, cut around the parts with a hobby knife or lightly sand the back of the sheet. After removing the die-cut parts, use your sanding block to **lightly** sand the edges to remove any die-cutting irregularities.
3. As you identify and mark the parts, separate them into groups, such as **fuse** (fuselage), **wing**, **fin**, **stab** (stabilizer) and **hardware**.

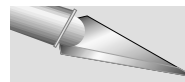

EXPERT TIP
EXPERT TIP

Zipper-top food storage bags are handy to store the small parts as you sort, identify and separate them into sub-assemblies.

4. Work on a flat surface. Cover the plan with wax paper or Great Planes Plan Protector to prevent glue from sticking to the plan.
5. When instructed to **test fit** parts, this means **DO NOT USE GLUE** until you are satisfied that everything fits properly — **THEN** glue the parts together if instructed to do so.
6. Whenever the instructions tell you to **glue** pieces together, use CA. When a **specific** type of glue is required, the instructions will state the type of glue that is **highly recommended**. When 30-minute epoxy is **specified**, it is highly recommended that you use only 30-minute (or slower) epoxy because you will need either the working time and/or the additional strength.
7. The easiest way to cut balsa sticks is with a single-edge razor blade or razor saw. Position the stick over the plan, mark its size, then cut the part on a piece of leftover wood. A modeling miter box works well for cutting square corners and 45-degree gussets.

DIE-CUT PATTERNS

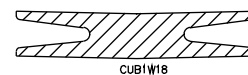
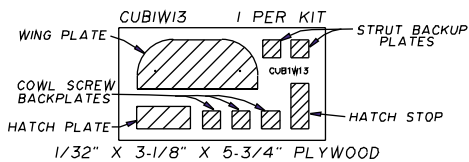
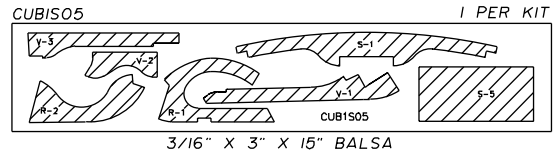
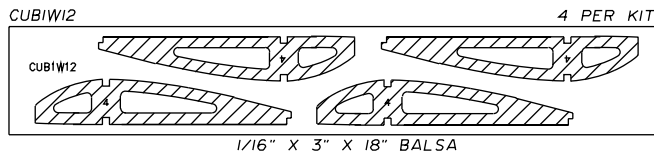
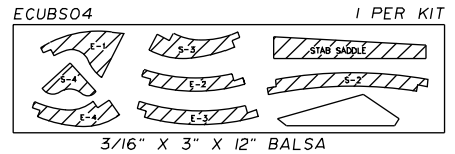
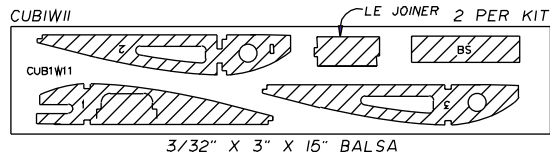
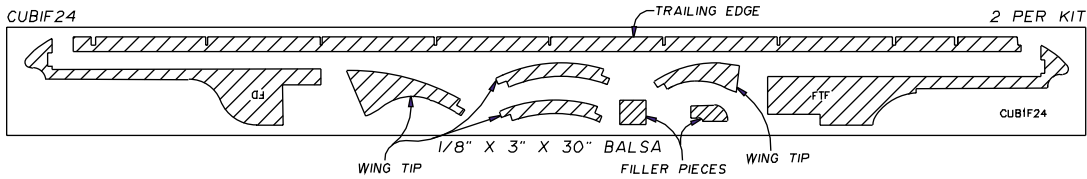
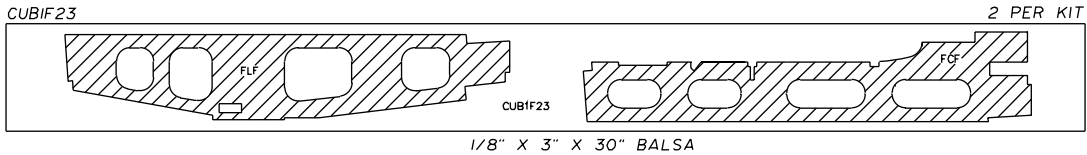
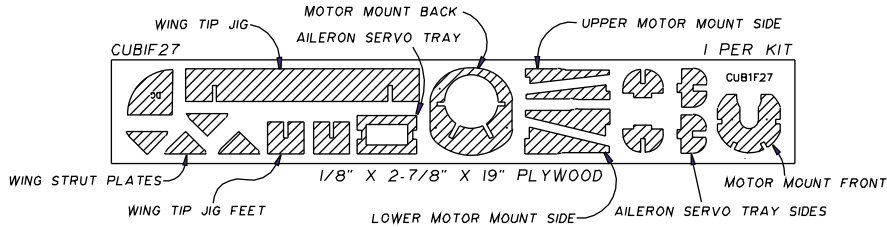
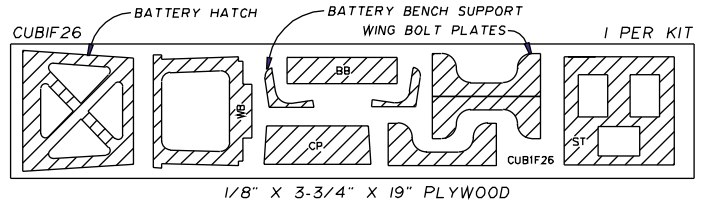
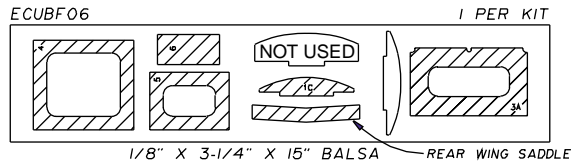
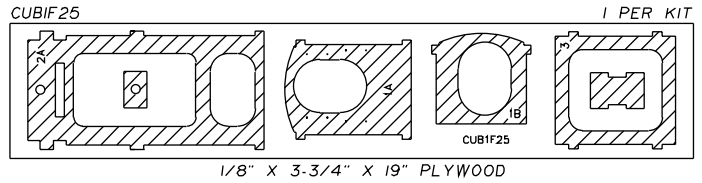
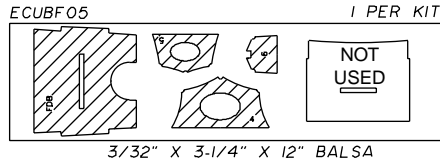
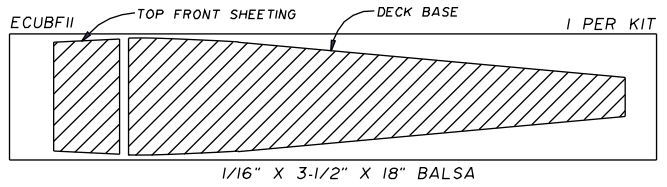
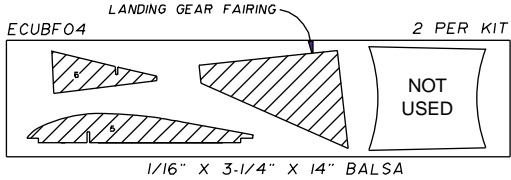

BUILD THE TAIL SURFACES

Build the Fin & Rudder

- 1. Cover the fin/rudder portion of the plan with wax paper or Great Planes Plan Protector.

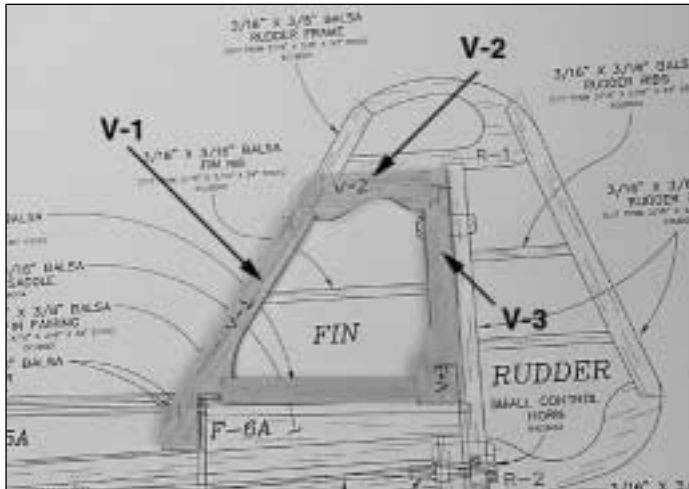

- 2. Pin the die-cut 3/16" balsa fin frame V-1, V-2 and V-3 in position on the fuse plan, sanding the mating edges as required for a good fit. Use thin CA to glue the fin frame together.
- 3. From one of the 3/16" x 3/8" x 30" balsa sticks, cut and glue a fin base between V-1 and V-3 along the bottom of the fin.
- 4. From the 3/16" x 3/16" x 24" balsa stick, cut and glue the fin rib to the frame.
- 5. Remove the fin from your building board. Inspect all the glue joints and add CA to any joints that don't look strong. Fill any gaps with balsa sanding dust and a drop or two of thin CA.



- 6. Build the rudder frame from the die-cut 3/16" balsa R-1 and R-2 frame pieces, a 3/16" x 3/8" x 30" balsa stick and the small 3/16" x 3/8" x 5/8" hardwood tailgear support.

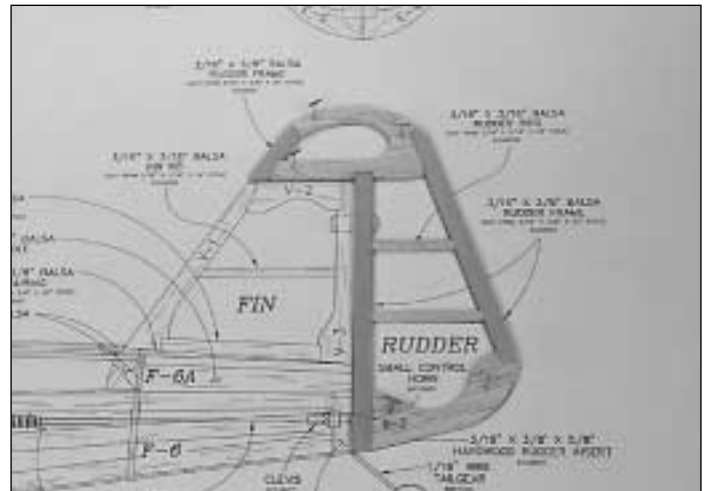

- 7. From the 3/16" x 3/16" x 24" balsa stick, cut and glue the rudder ribs to the frame.
- 8. Remove the rudder from your building board. Inspect all the glue joints and add CA to any joints that don't look strong. Sand the rudder and fin to shape using the fuse plan as a guide. Sand both sides of the rudder and fin flat and even. Be careful that you don't sand any area too thin.

Build the Stabilizer & Elevator

- 1. Cover the stabilizer/elevator portion of the plan with wax paper or Great Planes Plan Protector.
- 2. From one of the 3/16" x 3/8" x 30" balsa sticks, cut the stabilizer trailing edge to match the stabilizer plan. Pin the stab TE over the plan.

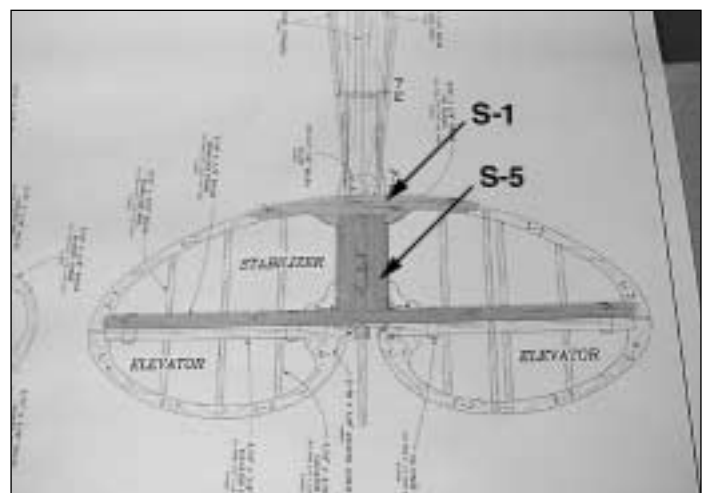

- 3. Pin the die-cut 3/16" balsa leading edge S-1 and stab center S-5 in position. Glue S-1 to S-5 and S-5 to the front of the stab TE.

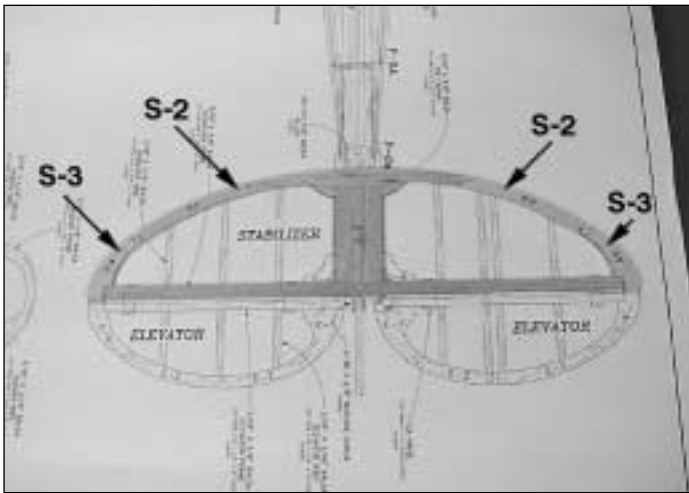

□ 4. Pin the die-cut 3/16" balsa **stab frames S-2** and **S-3** in position. Glue S-2 and S-3 to S-1 and the stab TE.

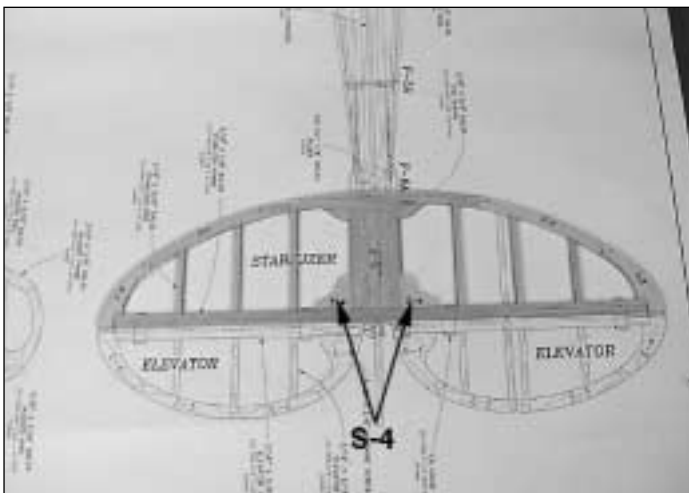

□ 5. From the 3/16" x 3/16" x 24" balsa stick, cut and glue the **stab ribs** to the stab frame. Glue the 3/16" die-cut balsa **stab gussets S-4** to the stab TE and S-5.

□ 6. Remove the stab from your building board. Inspect, glue and sand as you did with the fin.

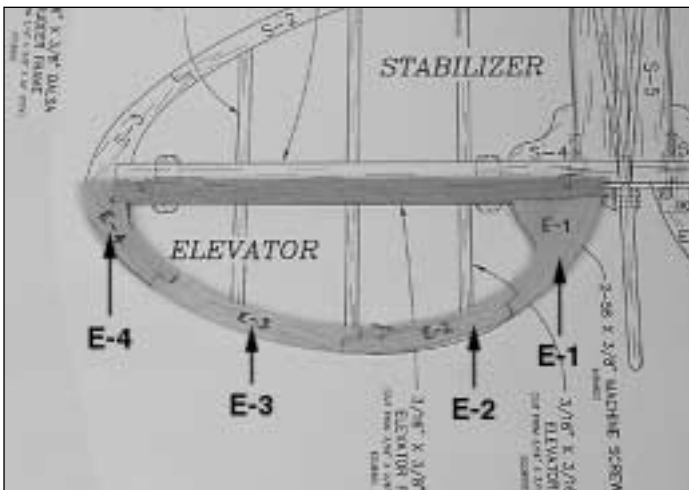

□ □ 7. From a 3/16" x 3/8" x 30" balsa stick, cut the **elevator leading edge** to length and pin it over the elevator plan. Pin

and glue the die-cut 3/16" balsa **elevator frame E-1** through **E-4** to the LE.

□ □ 8. From the 3/16" x 3/16" x 24" balsa stick, cut and glue the **elevator ribs** to the frame.

□ 9. Repeat steps 7 and 8 to build the second elevator half.

□ 10. Remove the elevators from your building board. Inspect, glue and sand as you did with the fin.

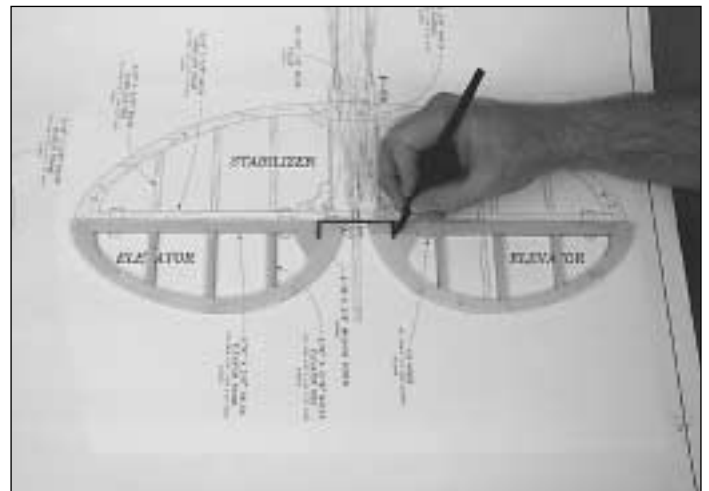

□ 11. Pin both elevators in position over the plan. Lay the 3/32" **elevator joiner wire** on top of the elevators in the position shown on the plan. Use a pencil to lightly mark the outline of the joiner wire on the elevators.

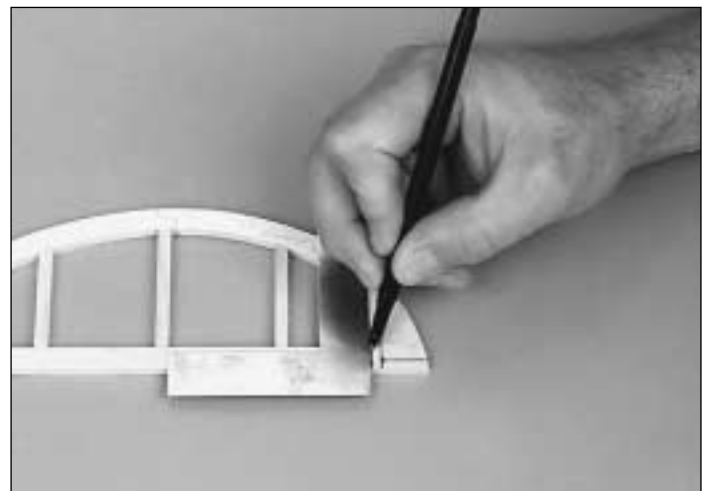

□ 12. Using a straightedge, extend the side lines of the elevator joiner outline forward to the leading edge. Also, use a **Precision Hinge Marking Tool** to draw a **centerline on the leading edge**. Using these lines, you can determine exactly where to drill the holes for the elevator joiner wire.



□ 13. Drill a 3/32" hole into the leading edge of both elevators. As you drill each hole, keep the drill aligned with the top and bottom surface of the elevator and reference lines you made in the previous steps.

□ 14. Refer to the Expert Tip that follows or use a Great Planes Groove Tube™ to cut a 3/32" groove in the leading edge of both elevators to recess the joiner wire.



HOW TO CUT A GROOVE FOR A JOINER WIRE



A. Use a #11 knife blade to sharpen the inside of a piece of 3/32" brass tube. Roll the tube as you carve the end.

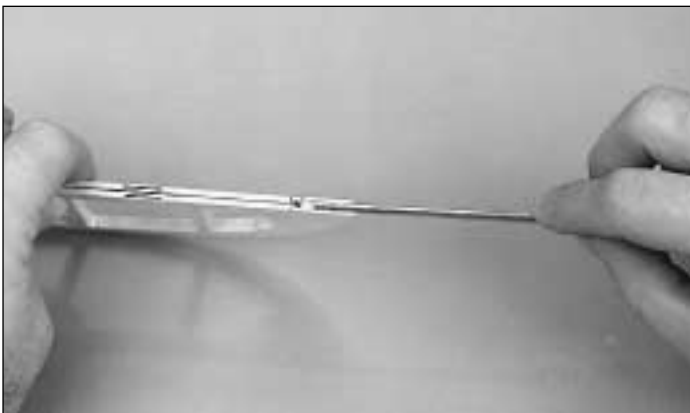

B. Use the sharpened tube to *carefully* gouge the leading edge of the elevators. You'll have to make several passes to make the recess deep enough for the joiner wire.

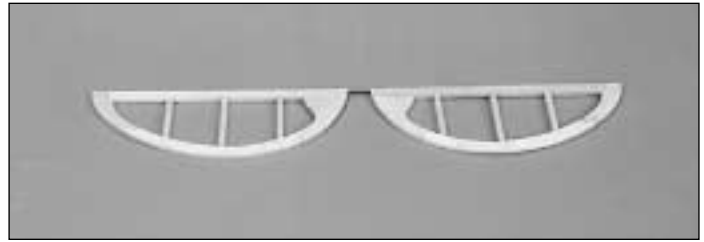

□ 15. Temporarily join the elevators with the joiner wire. The joiner wire will be easier to install if you chamfer (bevel) the ends a little. If necessary, "tweak" the joiner wire so the elevators are parallel and lay flat on your building table when the joiner wire is installed. If you found it necessary to "tweak" the joiner wire, use a felt-tip pen to mark it so you can install the joiner wire in the same orientation when you permanently join the elevators.

□ 16. Lay the elevators and stab over the plan and lightly mark the hinge locations on the LE of the elevators and the TE of the stab. Repeat the process to mark the hinge locations on the LE of the rudder and TE of the fin.



We have simplified the task of cutting hinge slots with the introduction of the **Great Planes Slot Machine™**. This simple electric tool cuts a perfect width slot for use with CA hinges.



To cut the hinge slot, place the blades onto the wood where you want the slot. Lightly press the teeth into the wood. When you are satisfied with the location, press the button on the handle and the blades will cut easily into the balsa wood.

If you choose not to purchase a Slot Machine™ you can make the slots by following these instructions.

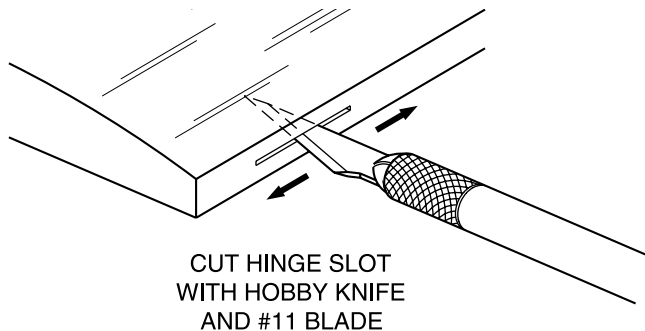

□ 17. Cut the hinge slots in the elevators, stabilizer, fin and rudder using a Hobby Knife with a #11 blade. Begin by carefully cutting a very shallow slit at the hinge location to accurately establish the hinge slot. Make three or four more cuts, going a little deeper each time. As you cut, slide the knife from side to side until the slot has reached the proper depth and width for the hinge.

□ 18. Cut the 3/8" x 1" hinges for the elevator and rudder from the supplied 2" x 9" **hinge material**, then snip off the corners. **Temporarily** join the elevators to the stab and the rudder to the fin with the hinges, adjusting any hinge slots if necessary so they all align. **Do not glue in the hinges until you are instructed to do so.**

Finish the Tail Surfaces

□ 1. Refer to the Expert Tip that follows and shape the leading edge of the elevators and rudder to a "V" as shown on the plan.



HOW TO BEVEL THE LEADING EDGES



A. Place the leading edge of one of the elevators on your work surface and use your pen to mark a "bevel to" line on both sides, about 3/32" high.

Note: You will probably have to adjust the height of the elevator with card stock so your "bevel to" line is not too high.

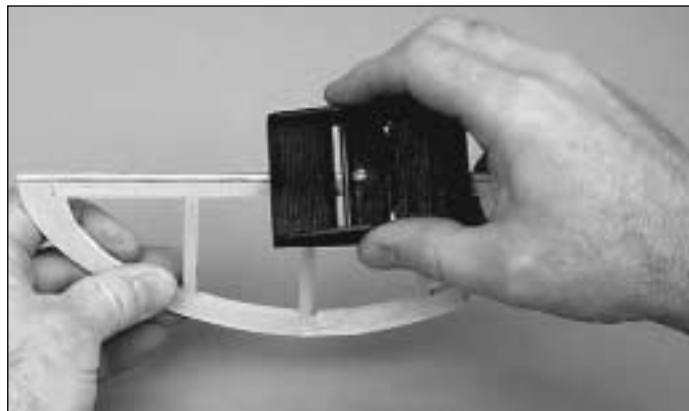

B. Using the "bevel to" lines and the centerline as a guide, make the "V" on the leading edge of the elevators with a razor plane or your bar sander with 150-grit sandpaper.

□ 2. Use the same procedure to bevel the leading edge of the rudder.

□ 3. Temporarily attach the elevators to the stab and the rudder to the fin. Use your bar sander to round the entire perimeter of the elevator, stab, rudder and fin (do not round the bottom edge of the fin where it will be glued to the stab and fuse).

BUILD THE WING

Build the Wing Panels

Start by building the left wing panel right side up over the left wing panel plan so your progress matches the photos.

□ 1. Set aside two of the hardest and straightest 1/4" x 1/4" x 13" balsa sticks for use later to make pushrods.

□ 2. The shaped and notched balsa wing leading edges are fastened together by a thin web of balsa. Separate the LE's by folding them until the balsa web breaks. Sand away the excess balsa that remains along the edges, using a sanding bar with 150-grit sandpaper. Before using the leading edge you must determine which one to use for the left wing panel. Here's how:

A. We have drawn a red line on the **top** of each piece.

B. The pieces are notched on one end but not on the other. The notched end goes toward the wing tip.

C. Position one of the leading edge pieces on the left wing panel plan with the red line up. If the notched end is on the left side (at the tip) you have the correct piece. (When building the right wing panel the red line must be up, with the notched end on the right side, at the tip).

□ □ 3. Cover the left wing panel plan with wax paper or Great Planes Plan Protector.

TWO WARPED SPARS INSTALLED THIS WAY WILL RESULT IN A STRAIGHT WING



TWO WARPED SPARS INSTALLED THIS WAY WILL RESULT IN A WARPED WING



□ □ 4. Match the 3/16" x 3/16" x 26-1/4" basswood **main spars** so any warps will counteract each other.

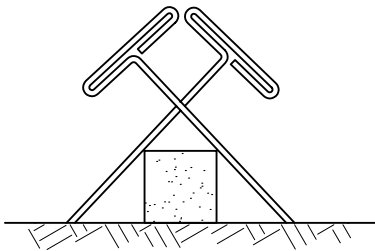

□ □ 5. Pin one of the main spars in position over the plan, aligning one end of the main spar with the outside edge of the tip rib W-4.

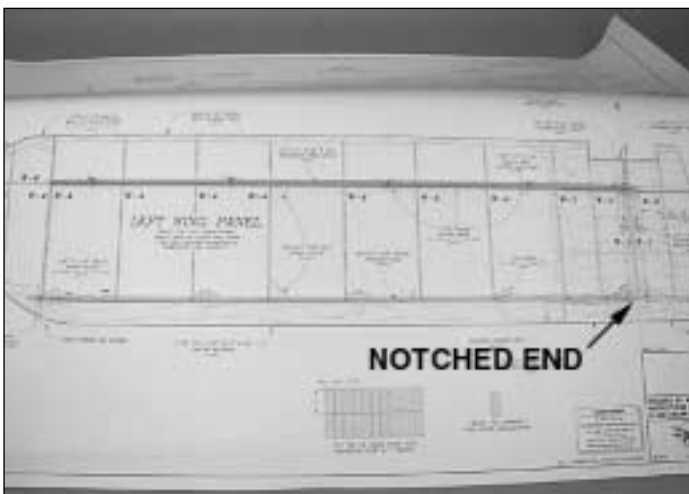

□ □ 6. Pin one of the die-cut 1/8" balsa trailing edges, notches facing up, in position over the plan. The TE is notched at one end and not the other. The notched end goes toward the wing root (wing center).

□ □ 7. Glue two of the die-cut 1/16" balsa **W-4** ribs together to make the tip rib.



□ □ 8. Place the W-4 ribs onto the main spar and into the notches in the trailing edge.



□ □ 9. Carefully insert the W-4 ribs into the notches in the leading edge. **Note:** Do not be concerned if the ribs do not line up exactly with the plan. Sometimes the humidity will cause the plan to expand or contract. Just make sure to line everything up with the outside edge of the last rib. The notches will provide the proper spacing.

□ □ 10. With the ribs, LE and TE flat against the building surface, glue the W-4 ribs to the spar, LE and TE.

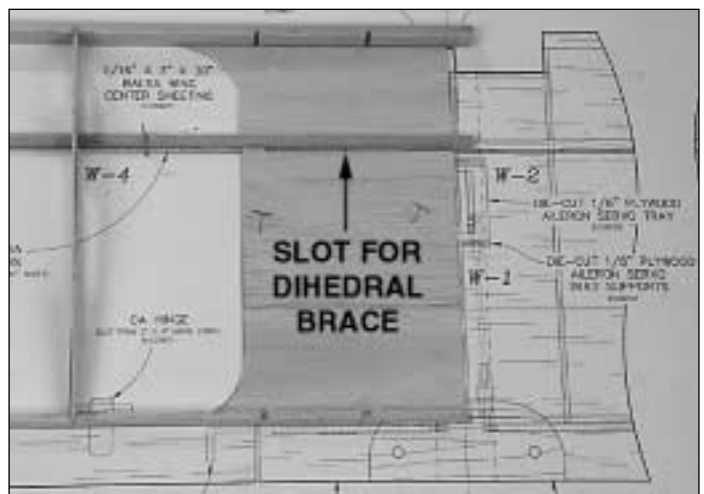

□ □ 11. From a 1/16" x 3" x 30" balsa sheet, cut the **wing center sheeting** to fit between the TE and main spar and the LE and main spar. Make sure to leave a 1/16" slot, for the dihedral brace, in the sheeting at the back of the main spar. Pin the sheeting in position. Then, glue the sheeting to the main spar, LE and TE.

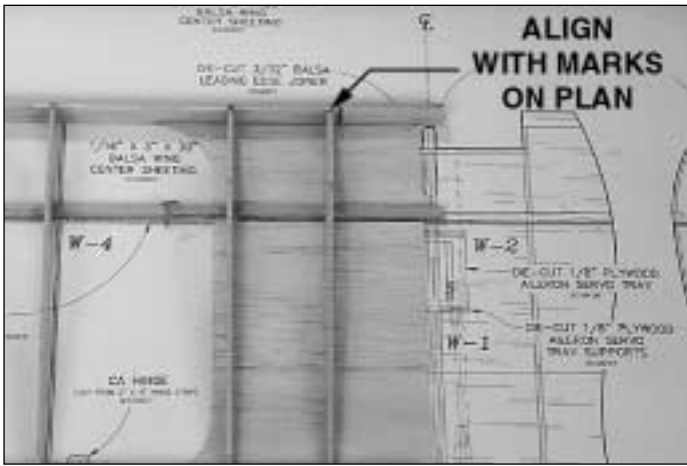

□ □ 12. Position the die-cut 3/32" balsa ribs **W-2** and **W-3** in position. **Important:** Rib W-2 does not fit into the notch in the LE. Rib W-2 fits into the notch in the TE and aligns with the alignment marks on the wing plan in front of the LE. **Glue only W-3** to the LE, TE, main spar and center sheeting.

□ □ 13. Position the top 3/16" basswood spar in the rib notches with one end flush with the outside edge of the tip rib and glue to all the ribs except W-2.

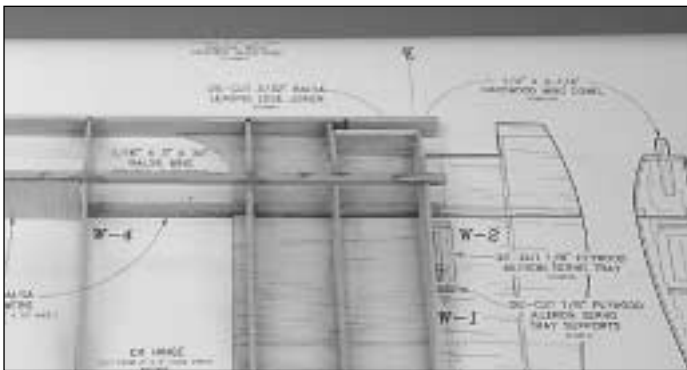

□ □ 14. Position the die-cut 3/32" balsa rib **W-1** in place between the main spars, with the bottom edge flat against the center sheeting. Use the die-cut 1/8" ply **dihedral gauge** to set the rib at the proper angle (see the drawing on the wing plan). Position the die-cut 3/32" balsa **LE joiner** between ribs W-1 and W-2. When you have W-1, W-2 and the LE joiner positioned properly, glue them in place.

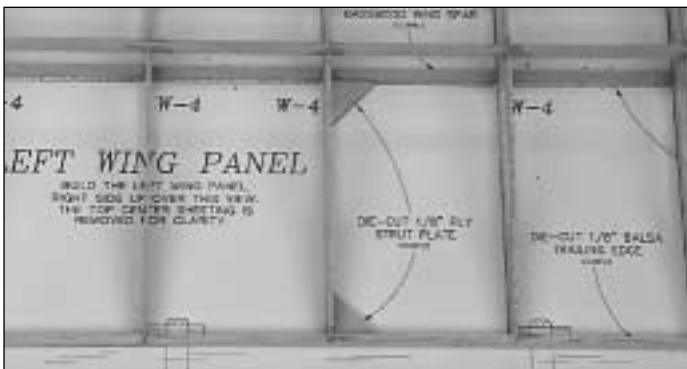

□ □ 15. Glue the two die-cut 1/8" ply **wing strut plates** in position. The wing strut plates must be flat on the table, flush with the bottom of the wing.



□ □ 16. From the 1/16" x 3" x 30" balsa sheet, cut and glue vertical grain **shear webs** to the spars in the locations shown on the plan. It is not necessary for the shear webs to be glued to the ribs. Make sure they are glued securely to the wing spars. **Do not install shear webs in the rib bays between ribs W-1 and W-3.**

□ □ 17. Carefully sand the top of the LE joiner flush with the top of ribs W-1 and W-2.

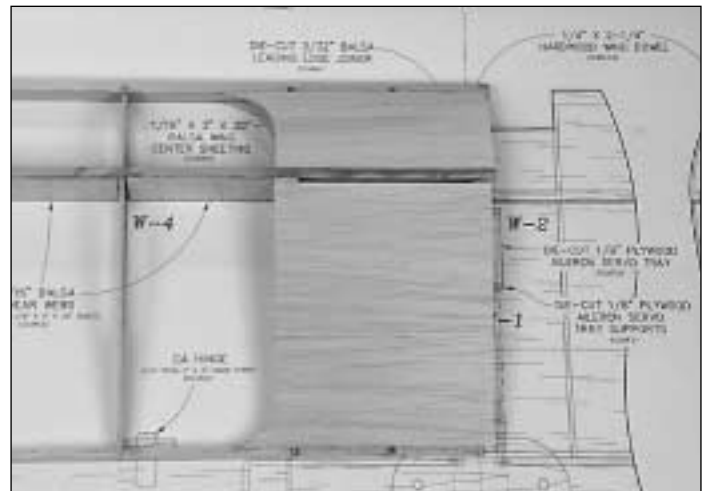

□ □ 18. From a 1/16" x 3" x 30" balsa sheet, cut pieces to make the top center section sheeting (don't forget the 1/16" notch for the dihedral brace). When satisfied with the fit, apply medium CA to the top of the ribs and press the sheeting in place. **Note:** If the balsa sheeting supplied in your kit is difficult to bend over the front portion of the ribs without cracking, wet the top surface of the sheeting with water. The water will soften the wood, making it much easier to bend.

□ □ 19. From one of the remaining 1/4" x 1/4" x 13" balsa sticks, cut four 1" long hinge blocks. Glue the **hinge blocks** in position, centered on the TE.



□ □ 19. Remove the wing from your building board. Use a razor saw to trim the LE and top and bottom center sheeting flush with rib W-2 and the LE joiner. Trim and sand the top and bottom main spars and center sheeting flush with the side of rib W-1. Sand the TE flush with the tip rib W-4.

□ □ 20. Sand the top and bottom of the LE and TE flush with the ribs.

□ □ 21. Now, go back to step 2 and build the right wing panel. **Remember!** Build it over the **right** wing plan.

Join the Wing Panels

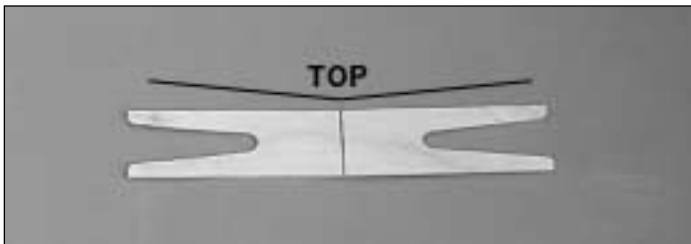

□ 1. Draw a centerline on the die-cut 1/16" ply **dihedral brace**. The top of the dihedral brace has a slight "V" shape.



□ 2. Using a razor saw, carefully cut a 1/16" slot in ribs W-1, just behind the main spar. Trial fit the dihedral brace in the slots.

□ 3. Sand the bottom of both wing panels near the center, to remove any excess glue on the spars or sheeting that may prevent the wing from resting flat on your building board.

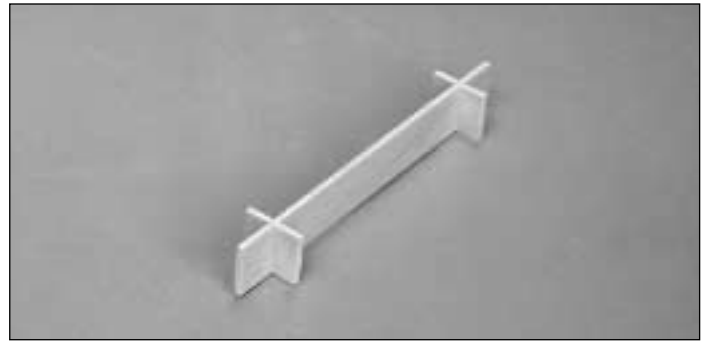

□ 4. Assemble the die-cut 1/8" ply **wing tip jig** and **wing tip jig feet**.

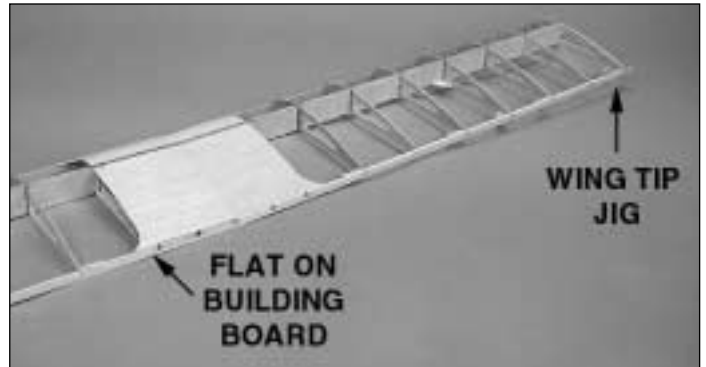

□ 5. Trial fit the wing halves together with one wing half flat on your building board and the wing tip jig under the tip rib of the other wing panel. Use a sanding bar to sand the center joint as necessary until the wing halves fit together without any gap.

□ 6. When satisfied with the fit, apply **30-minute epoxy** to the dihedral brace, main spars and ribs W-1. Do not apply epoxy within 1/4" of the wing dowel slot in W-1. You need to avoid getting epoxy in the slot. Slide the two wing halves together with the dihedral brace in place. With the two wing halves aligned, use masking tape to hold the wing halves together. Wipe off any excess epoxy with a paper towel dampened with rubbing alcohol. Weight one of the wing halves down flat on your building board, with the other wing half supported by the wing jig positioned at the wing tip. Allow the epoxy to cure before moving the wing.

Note: While waiting for the epoxy to cure, let's continue with assembling the wing tips.

Assemble & Install the Wing Tips

- 1. Cover the wing tip portions of the wing plan with wax paper or Great Planes Plan Protector.

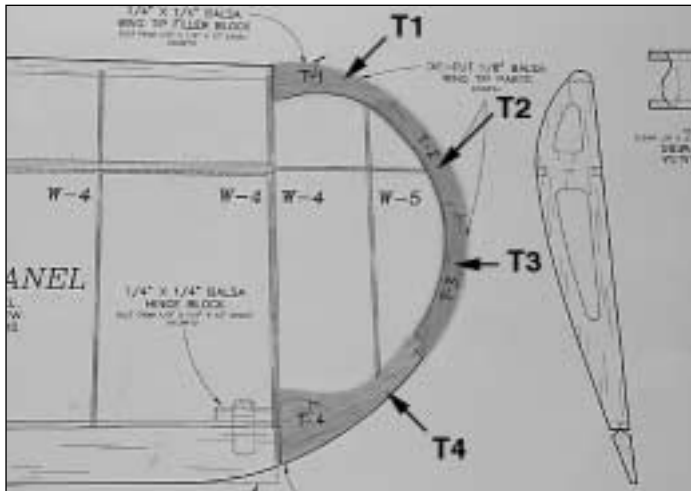

- □ 2. Assemble the **wing tip** from the die-cut 1/8" balsa parts **T-1**, **T-2**, **T-3** and **T-4**. There are two of each part (one for each wing tip). Position the wing tip parts over the plan and glue them together. Fill any gaps with medium CA, then sand smooth.

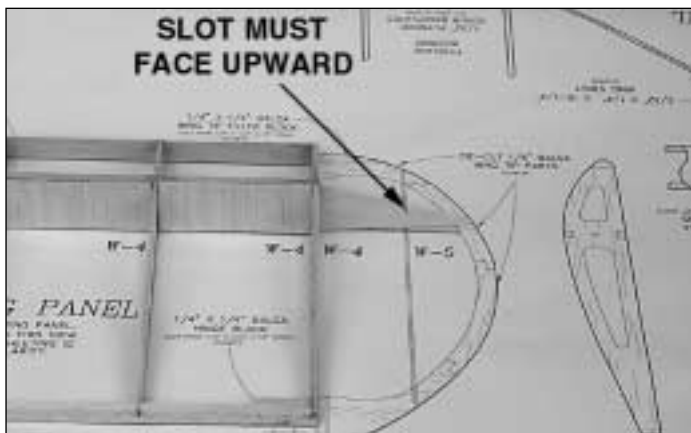

- □ 3. With one of the wing panels flat on your building table, glue the die-cut 1/16" balsa **wing tip brace W-6** to the end of the spars and tip rib **W-4**. **The slot in W-6 must be facing upward.**

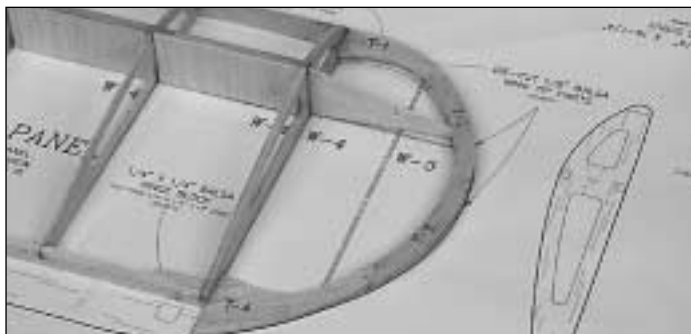

- □ 4. Trial fit the wing tip assembly against the end of the LE and TE. Center the LE of the wing tip on the end of the

wing LE. The TE of the wing tip should rest on the building table. Sand off the end of **W-6** until it just touches the inside edge of the wing tip.

- □ 5. With the wing tip centered on the LE and resting on the table at the TE, glue the wing tip to the LE, TE and **W-6**.

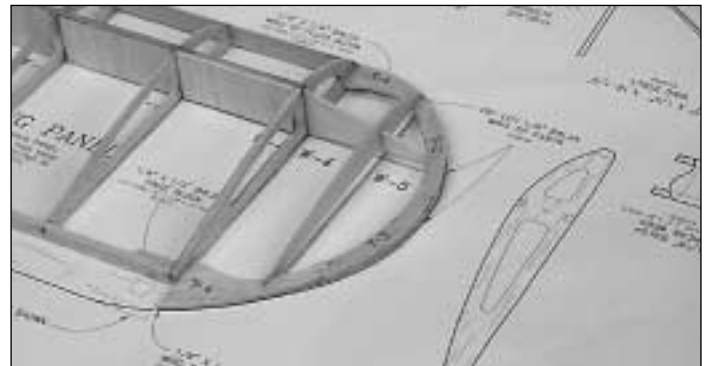

- □ 6. Trial fit the die-cut 1/16" balsa **rib W-5** in the notch in **W-6**. Sand the rib if necessary for a good fit and glue in place.

- □ 7. Sand the front and rear of **W-5** to blend into the rib contour.

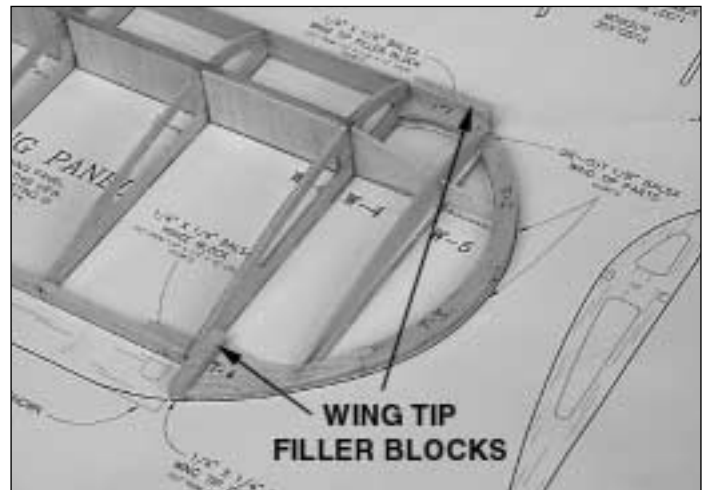

- □ 8. From a 1/4" x 1/4" x 13" balsa stick, cut and glue **wing tip filler blocks** on the top and bottom of the wing tip LE and on the top of the wing tip TE.

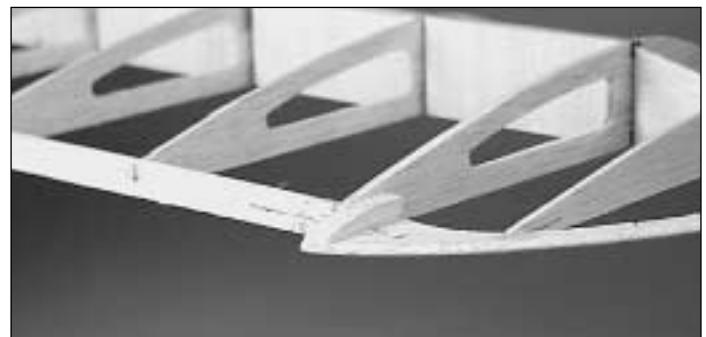

- □ 9. Use a sanding bar to blend the filler blocks into the wing tip. Round the edges of the wing tip.

- 10. Go back to step 2 and assemble the other wing tip.

Build the Ailerons

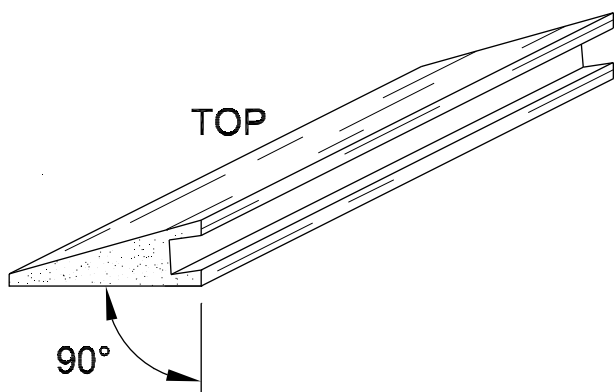
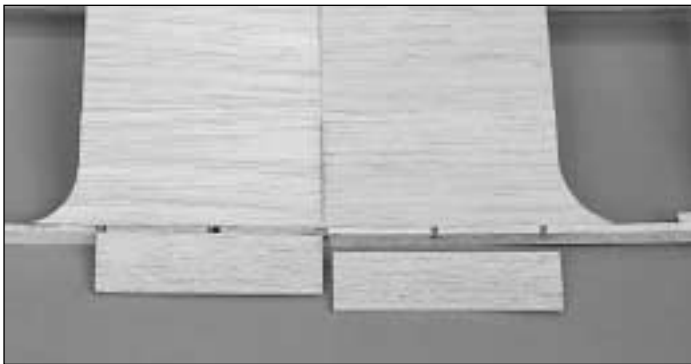

- 1. Cut the tapered and grooved balsa **center trailing edges** to the length shown on the plan. Bevel them so they join as shown on the plan. Test fit the center TE's on the wing. **Note:** The center TE is positioned on the wing with the 90 degree edge at the bottom of the wing.

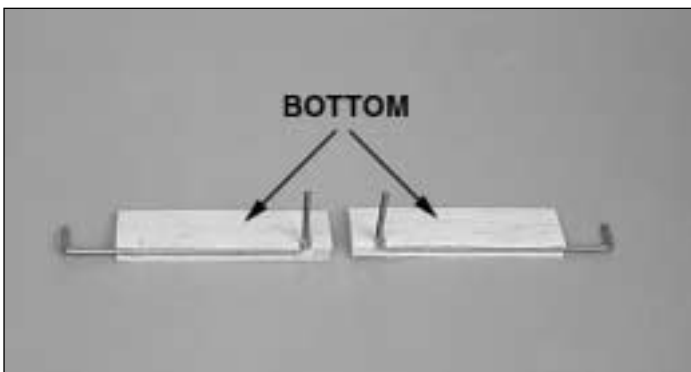

- 2. Place the center TE's over the wing plan and mark the location of the **aileron torque rods**. To clear the torque rods, cut notches at the marks on the **bottom** of the center TE's. Test fit the torque rods in the center TE's to check for clearance.

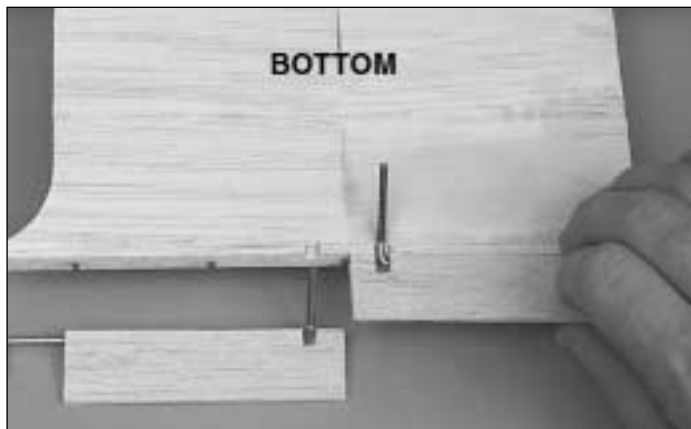

- 3. Turn the wing upside-down and position the center TE's on the wing TE with the torque rods installed. Mark the location of the notches on the bottom of the wing's TE. Cut notches in the wing TE at the marks. Test fit the center TE's with the torque rods installed, checking that the notches align and are large enough to allow the torque rods to move freely.

- 4. Use coarse sandpaper to scuff the **nylon tube bearing** on the aileron torque rods so that the glue will adhere better.

- 5. To prevent gluing the torque rod to the nylon tube bearing, apply petroleum jelly on the torque rod at the ends of the nylon tube bearing.

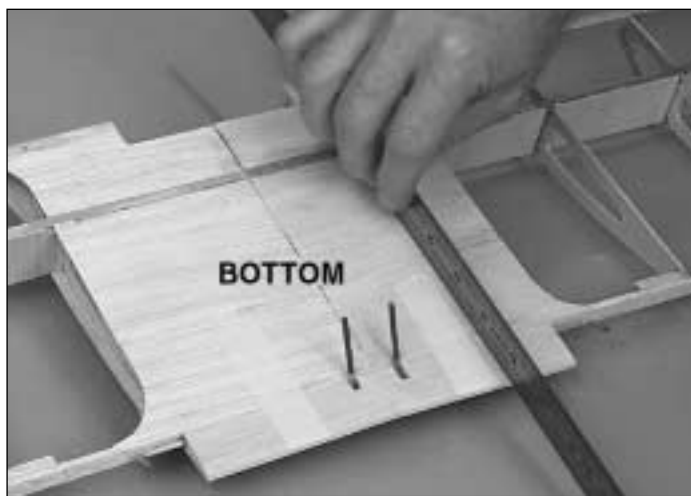

- 6. Use 30-minute epoxy to glue the nylon tube bearings in the center TE's and the center TE's to the TE of the wing. Tape the center TE's to the wing so that the bottom of the center TE's are aligned with the bottom of the wing. Use a paper towel dampened with rubbing alcohol to wipe off any excess epoxy before it cures.



□ □ 7. Position the left **aileron** on the trailing edge of the wing. Mark the end of the aileron where it meets the wing tip. Cut the aileron approximately 1/8" shorter than the mark. This will allow the aileron to move freely after the MonoKote® covering is applied.

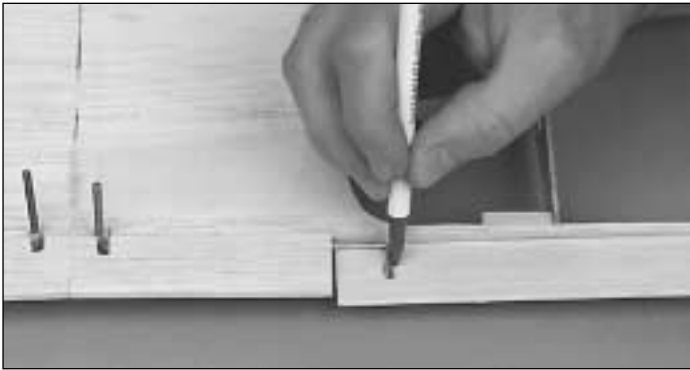

□ □ 8. Position the aileron on the wing with a 1/16" gap at each end. Mark the location of the torque rod on the aileron.



□ □ 9. Use a drafting square or triangle to extend the marks to the LE of the aileron. Mark an accurate centerline on the entire LE of the aileron and the TE of the wing.

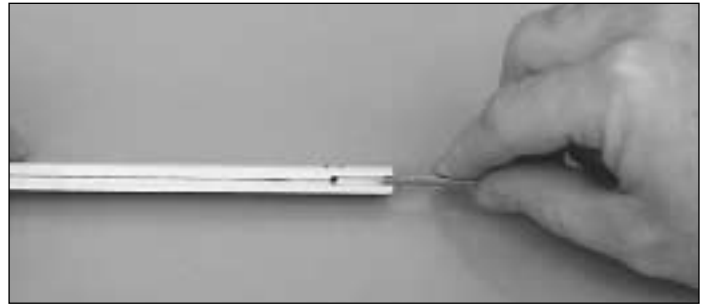

□ □ 10. Use the centerline and the marks for the torque rod as a guide to drill a 7/64" hole in the aileron for the torque rod. Use the Great Planes Groove Tube or a sharpened brass tube to cut a groove for the torque rod in the LE of the aileron.

□ □ 11. Test fit the aileron on the wing to make sure the torque rod fits and there is approximately 1/16" clearance between both ends of the aileron and wing.



□ □ 12. Mark the location of the hinges on the aileron and wing. Cut the hinge slots in the aileron and wing. Cut four 3/8" wide hinges from the supplied hinge strip. Insert the hinges in the aileron and fit the aileron to the wing. Do not glue the hinges at this time.



□ □ 13. Sand the tip of the aileron to blend with the wing tip.

□ □ 14. Remove the aileron from the wing. Mark the "bevel to" lines and shape the LE of the aileron to a "V" as shown on the plan.

□ □ 15. Go back to step 7 and fit the right aileron to the wing.

Finish the Wing

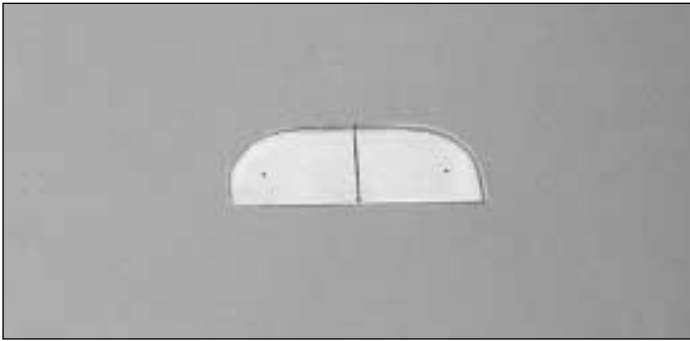

□ 1. Use a pen to draw a centerline on the die-cut 1/16" plywood **wing plate**. Use a sanding bar to bevel the front and sides of the wing plate to a sharp edge.

□ 2. Lightly sand the entire wing smooth. Sand very carefully in the center section area when removing the excess glue around the center joint (remember, the sheeting is only 1/16" thick).



□ 3. Use 6-minute epoxy to glue the wing plate on the **top** of the wing, aligned with the centerline and flush with the wing center TE. Use masking tape or clamps to hold it tight against the wing sheeting until the epoxy cures.

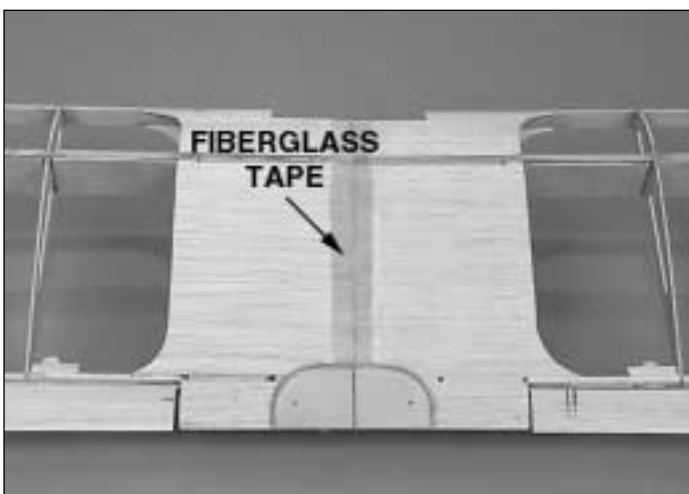

□ 4. Read "**Fiberglassing Tips**" that follow this step. The included strip of **fiberglass tape** is used to reinforce the center of the wing. The remaining fiberglass tape is used to reinforce the ends of the wing struts. With the wing upside-

down, use thin CA to glue the fiberglass tape to the center sheeting starting at the TE and working toward the LE. Then glue the tape on the top of the wing from the front edge of the wing plate to the LE. Cut off the excess tape.

Fiberglassing Tips: If you spray a very light mist of 3M "77" spray adhesive on the center section (only where the glass tape is to be applied), you can press the glass tape in place before applying the thin CA glue. Hold the spray can at least 16" away from the wing and give it just a short burst. You may also use a piece of wax paper to press the glass tape firmly down to the wood immediately after applying the CA.

□ 5. Use a sanding bar to **carefully** "feather" the edges of the glass tape into the center sheeting. Lightly sand the surface of the glass tape to remove the roughness, but **do not** sand through the weave. A light coat of balsa filler can also be used to blend the glass tape to the center sheeting.

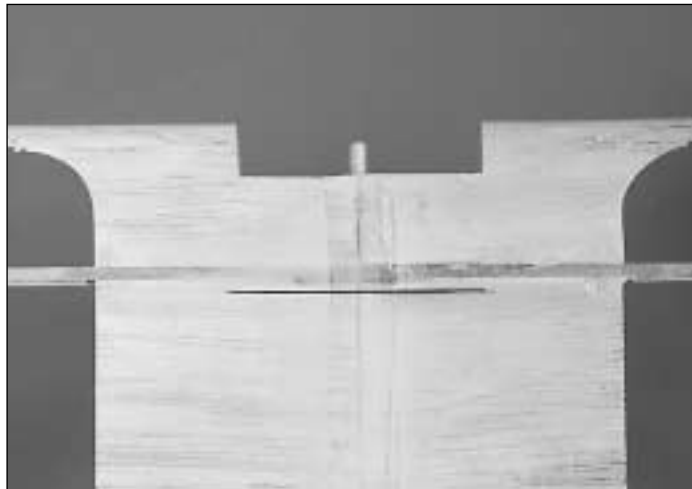

□ 6. On the bottom of the wing, draw a line 3/16" back from the aft edge of the wing spar.

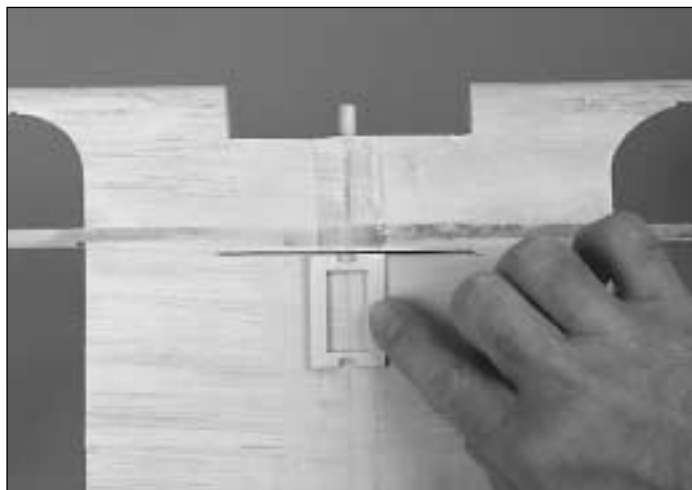

□ 7. Align the die-cut 1/8" ply **aileron tray** with the line, centered on the wing joint. Trace around the aileron tray.

BUILD THE FUSELAGE

Assemble the Fuselage Sides

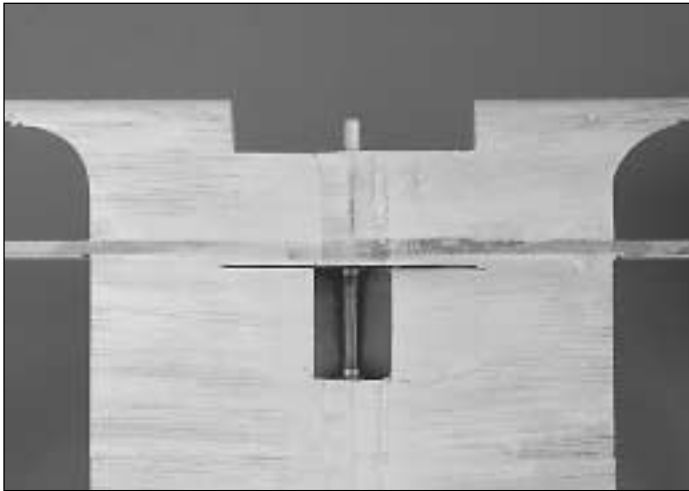

□ 8. Trim the 1/16" balsa sheeting along the outline of the aileron tray. Cut out the aileron servo opening in ribs W-1.

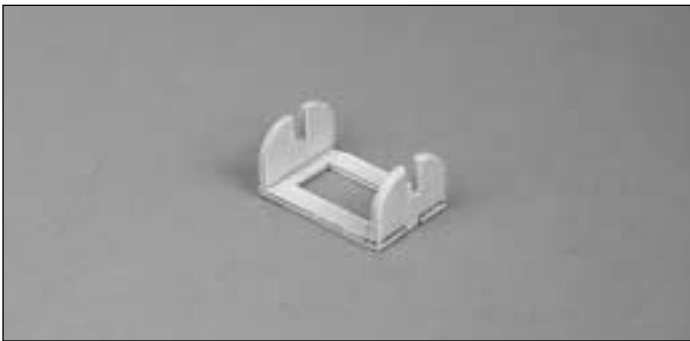

□ 9. Glue the die-cut 1/8" ply **aileron tray supports** on the end of the aileron tray, perpendicular to the tray.



□ 10. Insert the aileron tray into the opening in the wing and glue in position. Cut a small hole in the wing sheeting next to the aileron tray to route the servo wire out.

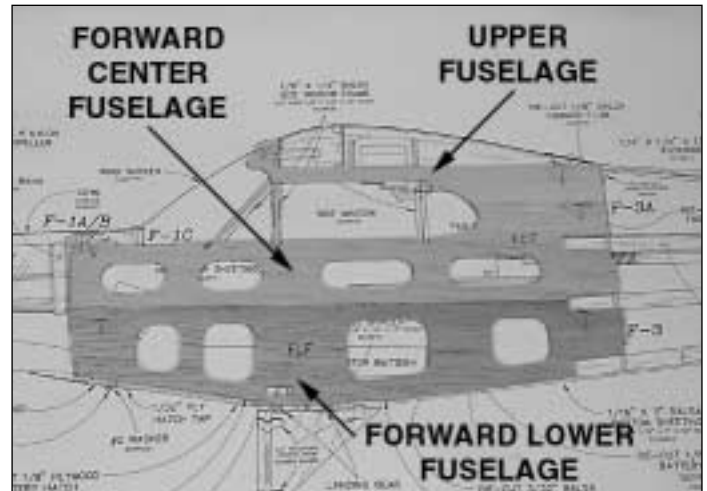

□ □ 1. With wax paper or Plan Protector positioned over the fuse plan, pin the die-cut 1/8" balsa **forward lower fuselage (FLF)**, **forward center fuselage (FCF)** and **upper fuselage (FTF)** in position over the plan and glue together.

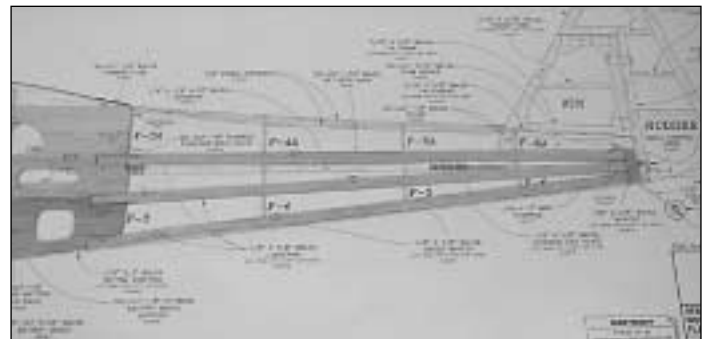

□ □ 2. From the 1/8" x 3/8" x 24" balsa sticks, carefully cut the three **longerons** and the **tail post** to match the plan. Glue the longerons to the forward fuselage and glue the tail post to the ends of the longerons.

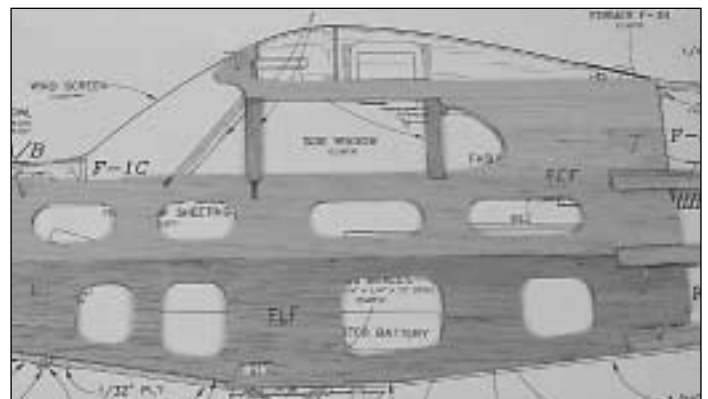

□ □ 3. From the 1/8" x 1/4" x 24" balsa stick, cut and glue the two **side window frames** to the forward center and upper fuselage sides.

□ □ 4. Use a pen to mark the location on the longerons for formers F-4, F-5 and F-6.

□ 5. Remove the fuselage side from the plans. Return to step 1 and build the second fuselage side.

□ 6. Place the two fuse sides together and check that they match up all the way around. If they are not identical, pin them together and use a sanding bar to make them match.

□ 7. Lightly sand both sides of the fuselage sides to remove any excess glue.

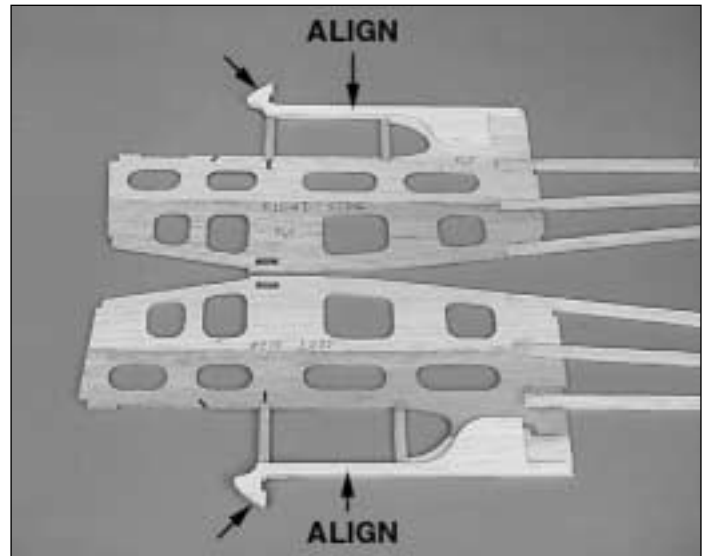

□ 10. Align and glue the die-cut 1/8" balsa **wing saddle doublers** to the inside of both fuse sides with the top and front of the doubler aligned with the top and front of the fuse side.

□ 11. Cut the 1/4" x 1/4" x 12" basswood **servo tray rail** in half.

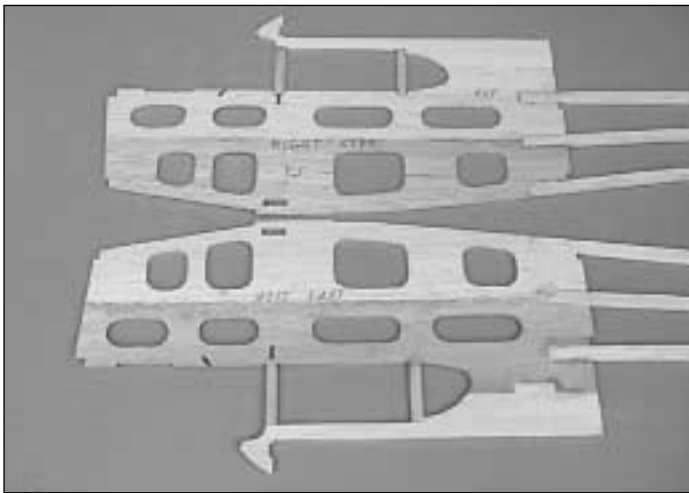

□ 8. Lay the fuse sides next to each other so they mirror each other. Mark one fuse side **left side** and one **right side**.

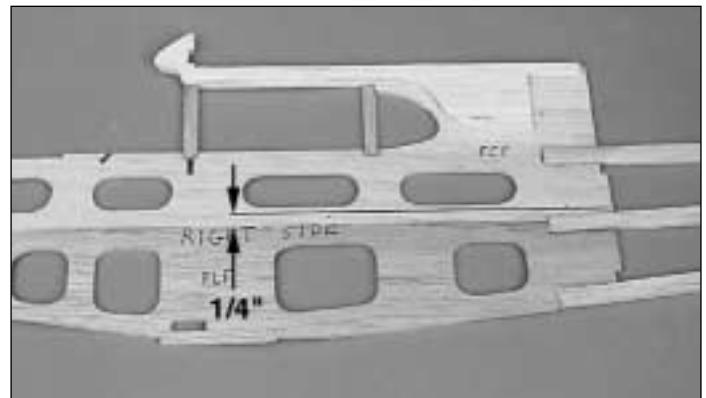

□ □ 12. Draw a line on the inside of the fuse sides, 1/4" above the joint between the forward lower fuse and the forward center fuse.

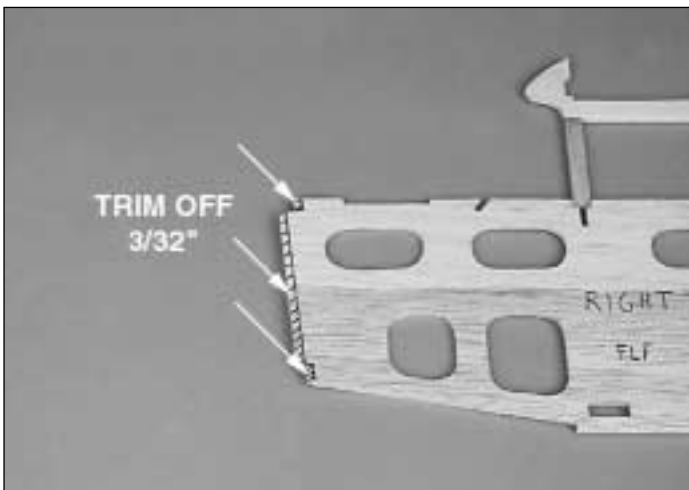

□ 9. To provide right thrust in the firewall, trim 3/32" off the front of the right fuselage side.

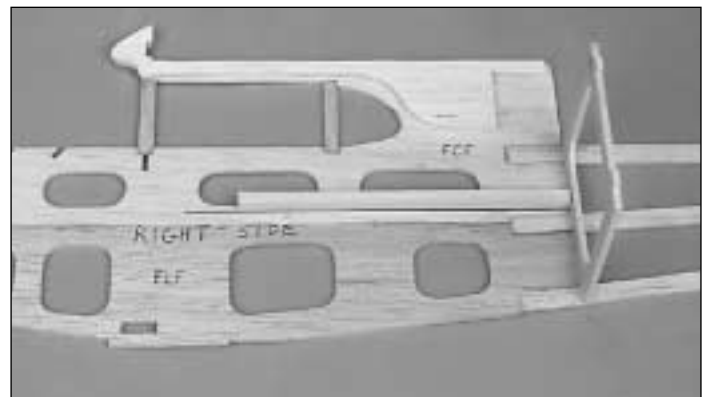

□ □ 13. Temporarily install the die-cut 1/8" plywood **former F-3** in position on the fuse side. Glue the 1/4" x 1/4" servo tray rail to the fuse side, aligning its bottom edge with the line drawn in step 12 and former F-3. Do not glue the rail to F-3.

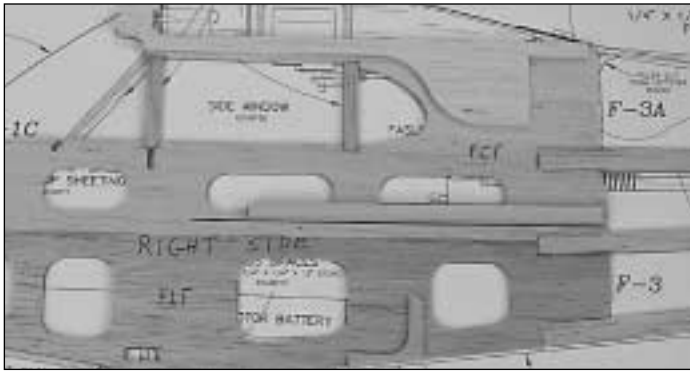

□ □ 14. Position the fuse side over the plan and glue the die-cut 1/8" plywood **battery bench support** to the inside of the right fuse side. When assembling the left side, position the fuse over the plan and mark the location of the battery bench support on the outside of the fuselage. Then, transfer the lines to the inside of the fuselage and install the bench support.

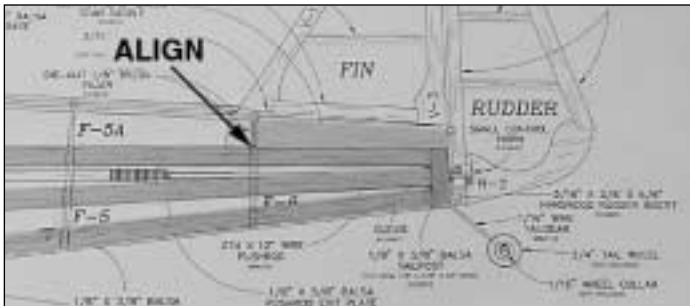

□ □ 15. Glue the die-cut 3/16" balsa **stab saddle** to the top of the longeron. Make sure the front of the stab saddle aligns with the mark for the aft edge of former F-6.

□ 16. Return to step 12 and repeat the steps to assemble the left fuse side.

□ 17. Transfer the marks for the formers to the other side of the longerons on the fuse sides.

Join the Fuselage Sides



□ 1. From the leftover 1/4" x 1/4" balsa stick (don't use the two that have been set aside for making the pushrods) cut and glue reinforcements to both sides, at the bottom of the die-cut 1/8" plywood **former F-2A**. Make sure the sticks are flush with the end of the tabs.

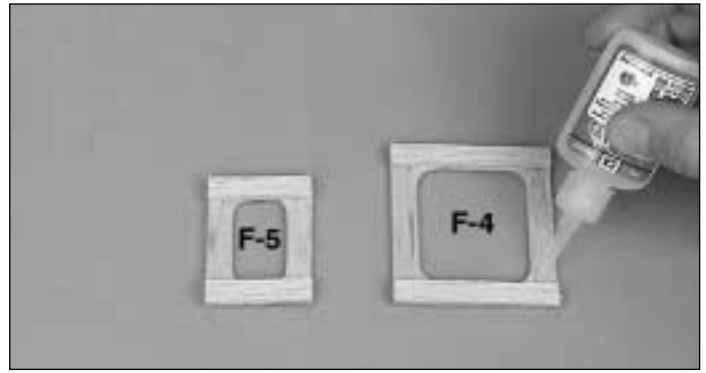

□ 2. From the leftover 1/8" x 3/8" balsa stick, cut two pieces the full width of the die-cut 1/8" balsa **formers F-4** and **F-5**. Glue the sticks to the aft side at the top and bottom of the formers.

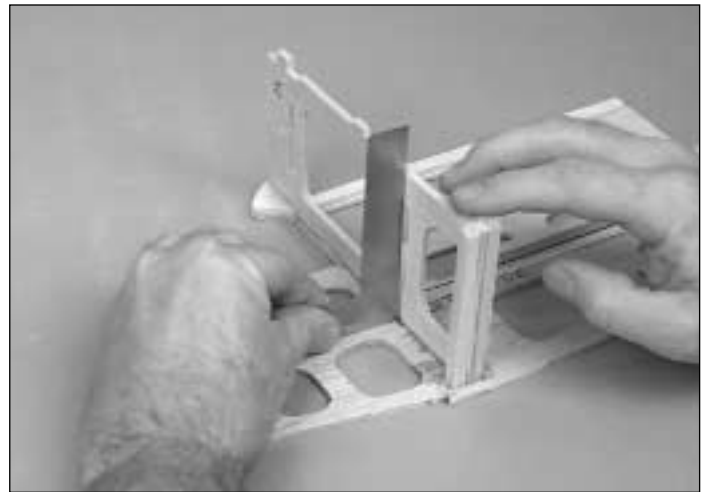

□ 3. Install former F-2A on the right fuse side so that the embossed F-2A faces forward. Make sure F-2A is inserted into the notches completely. Use a building square to hold F-2A perpendicular to the fuse side while gluing the former in place.

□ 4. Glue the die-cut 1/8" plywood **former F-3** to the right fuse side. Use a building square to hold F-3 perpendicular to the fuse side while gluing the former in place.

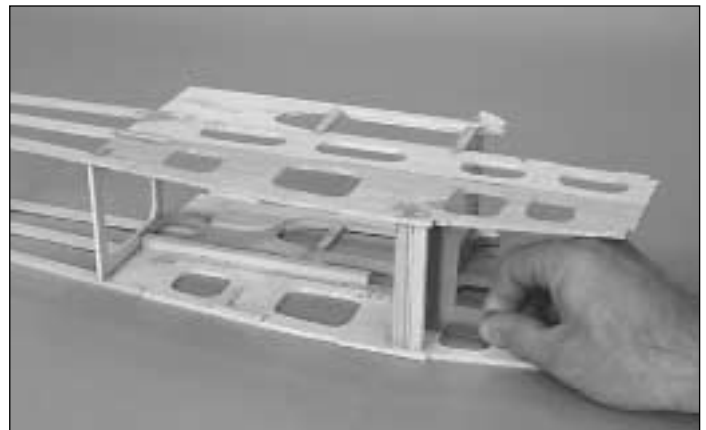

□ 5. Join the right fuse side to the left, keying formers F-2 and F-3 to the left fuse side. Lay the fuse on its left side and glue F-2 and F-3 to the left fuse side, making sure they are perpendicular to the fuse side. It may help to prop up the aft end of the right fuse side while performing this step.

□ 6. Pull the tail posts together and use a bar sander to lightly sand the inside edges of the tail posts to an angle. Align the fuse over the fuselage top view, checking the tail posts for the proper width. Carefully line up the tail post and glue them together. **Note:** A small misalignment here will throw the aft end out of line, so double-check before gluing.

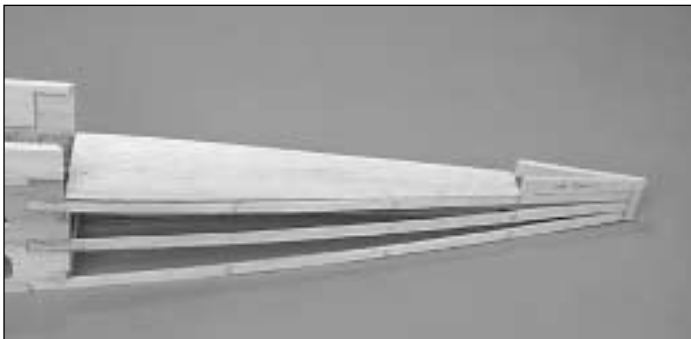

□ 7. Test fit the die-cut 1/16" balsa **aft deck base** between the forward center fuse sides and the stab saddle. Trim the aft end of the deck base for a good fit.

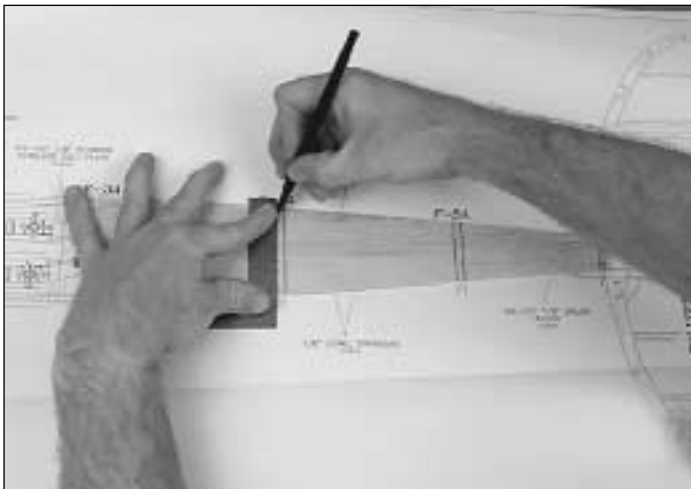

□ 8. Pin the aft deck base to the plan top view (note that the front of the deck base is flush with the front of F-3). Use the former locator marks and draw the former location lines on the aft deck base.

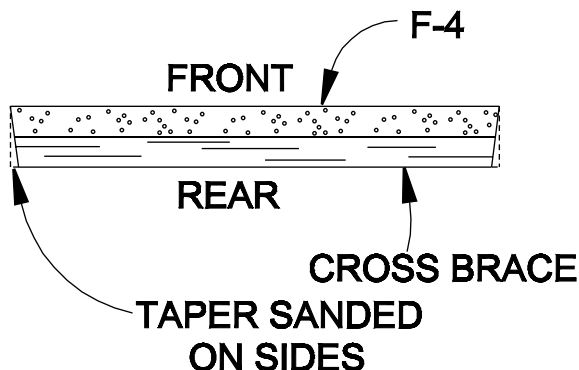

□ 9. Trial fit former F-4 between the longerons at the former location lines (the cross braces face aft). Note that the sides

of F-4 and the cross braces will have to be sanded to a slight taper to make good contact with the longerons. Remove F-4 and sand as required for a good fit. Do not glue F-4 to the longerons.

10. Repeat the above process to properly taper the sides of F-5 and F-6.

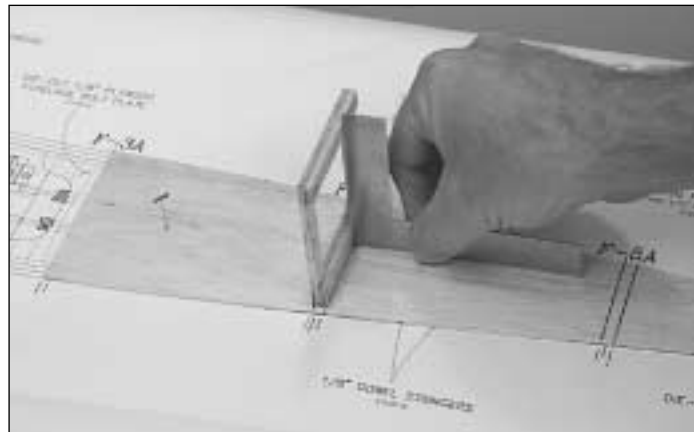

□ 11. Position F-4 between the former location lines on the aft deck base. Adjust the position of F-4 so it is centered between the edges of the aft deck base. Glue F-4 to the aft deck base, perpendicular to the aft deck base.

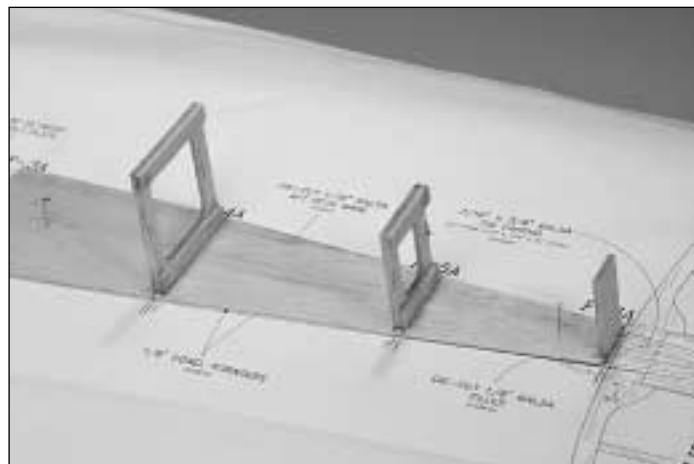

□ 12. Repeat the procedure, gluing F-5 and F-6 to the aft deck base. Remove the deck base from the plan.

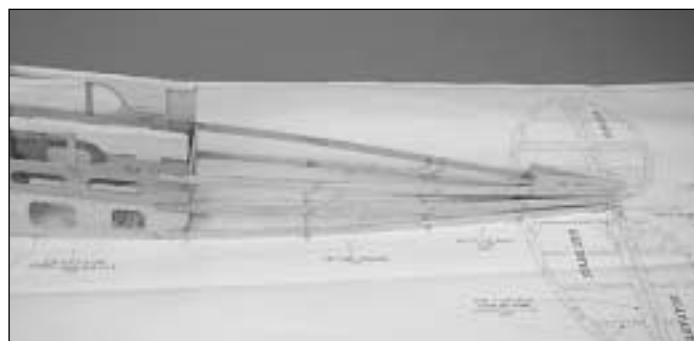

□ 13. Pin the fuselage over the plan top view. Make sure former F-3 and the tail post are aligned with the plan. Check that the sides of the tail posts are perpendicular to the building board.

□ 14. Trial fit the aft deck base and formers on the fuse. At each former, make sure the deck base seats completely on the top longeron. Lightly sand the bottom of the formers as needed.

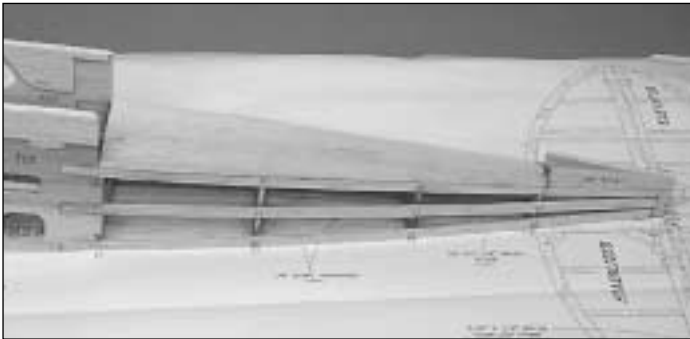

□ 15. Glue the aft deck base to the top edge of former F-3. While applying pressure on the aft deck base at F-4, glue the top longeron to the aft deck base at F-4. Repeat the process at F-5 and F-6. Then, proceed to glue the top longeron to the rest of the aft deck base.

□ 16. Again, check that the tail post is perpendicular to the building board (when viewed from the rear). Glue the middle longerons to the formers. Temporarily apply weight to the aft deck base so that F-4, F-5 and F-6 are against the building board. Glue the bottom longerons to the formers.

□ 17. Turn the fuse upside-down and apply glue along the joints between the aft deck base and F-4, F-5 and F-6.

□ 18. Carefully sand the bottom of the fuse flat.

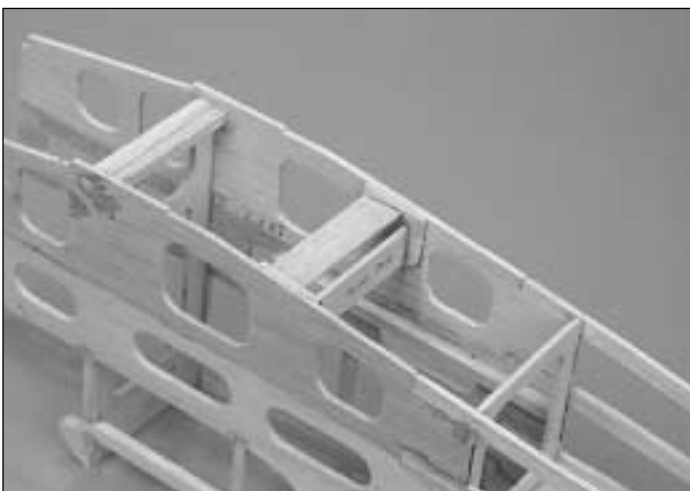

□ 19. Glue the die-cut 1/8" plywood **battery bench back** and the die-cut 3/32" balsa **battery bench seat** to the battery bench supports.

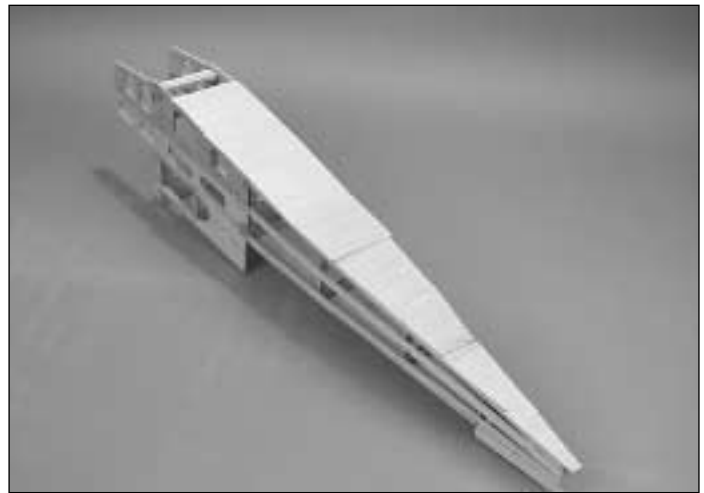

□ 20. Position the fuse upside-down on your building board. Check that the tail post is perpendicular to the building board (when viewed from the rear). Sheet the bottom of the fuse with 1/16" x 3" x 30" balsa sheet, applied cross-grain, starting at the rear edge of the landing gear plate opening and proceeding to the tail post. **Note:** A good way to do this is to lay the sheet across the fuselage and mark the edge of the longerons on the bottom of the sheet. Remove the sheet and cut along the mark with a hobby knife, allowing a little extra that will be sanded off later.

□ 21. Use a sanding block to sand the bottom sheeting flush with the sides of the fuse.

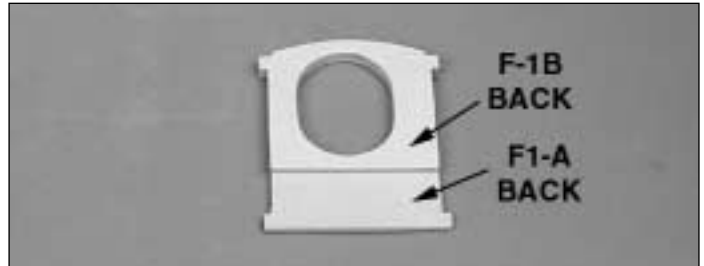

□ 22. Using epoxy, glue the die-cut 1/8" plywood **F-1B** to the **back** of **F-1A**. This is now called the **firewall**. Remember, the side with the embossed "1A" and "1B" is the front of the firewall.

□ 23. After the epoxy cures, drill 3/32" pilot holes through the firewall at each of the eight punch marks.

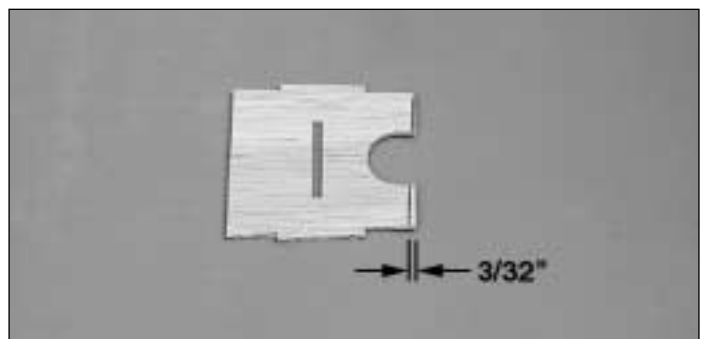

□ 24. Make a mark 3/32" from one front corner of the die-cut 3/32" balsa **front deck base**. Trim the end of the front deck base at an angle to allow for the right thrust in the firewall.

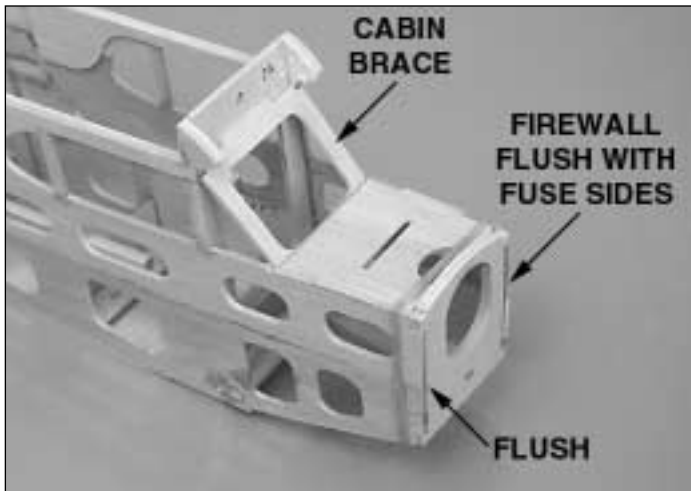

□ 25. Trial fit the die-cut 1/8" plywood **cabin brace** in former F-2 and the fuse sides. Lay the front deck base in position and then the firewall assembly, pulling the front of the fuse together with rubber bands. Sand the front deck base, as necessary, for a good fit.



To reduce weight, before installing the top front sheet cut lightening holes in the front deck as shown on the plan.

- 26. Glue the cabin brace to the fuse sides and F-2.
- 27. Glue the front deck base to the fuse sides and cabin brace.
- 28. Use 6-minute epoxy to glue the firewall to the fuse sides and the front deck base. Wipe off any excess epoxy with a paper towel dampened with rubbing alcohol. Hold the fuse sides tightly against the firewall until the epoxy sets.

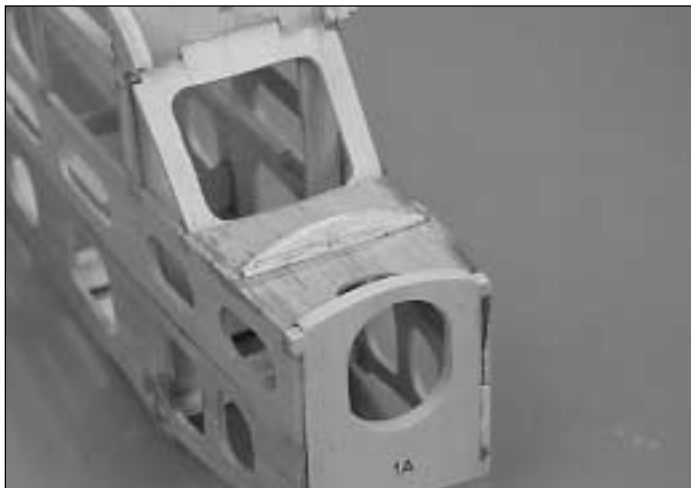

□ 29. Glue the die-cut 1/8" balsa **former F-1C** to the front deck base.

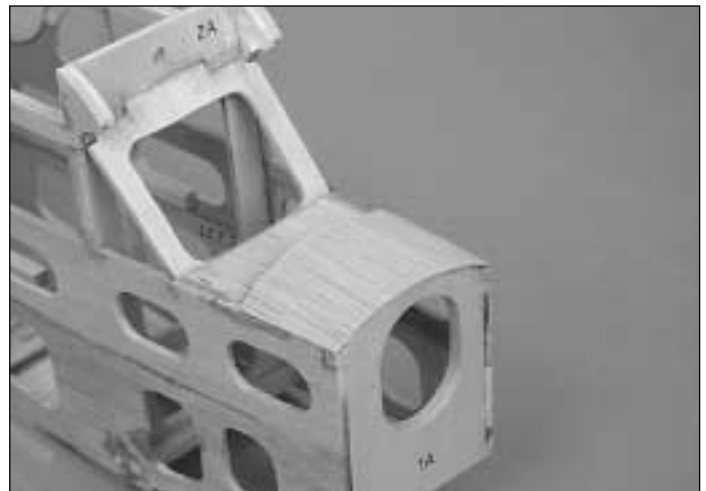

□ 30. Trial fit the die-cut 1/16" balsa **top front sheet**, sanding as necessary. Glue the front sheet to the firewall, F-1C and the front deck base. If the front sheet is hard balsa and difficult to bend, wet the top surface of the sheet with warm water before bending around the formers.

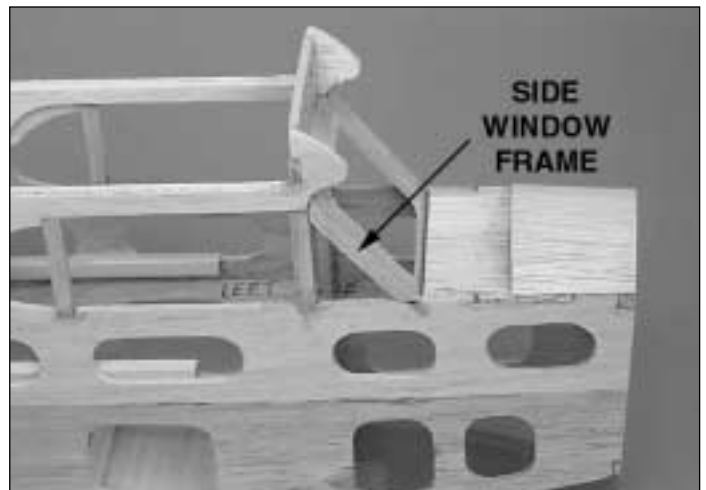

□ 31. From the leftover 1/8" x 1/4" balsa stick, cut side window frames to fit flush with the front of the cabin brace.

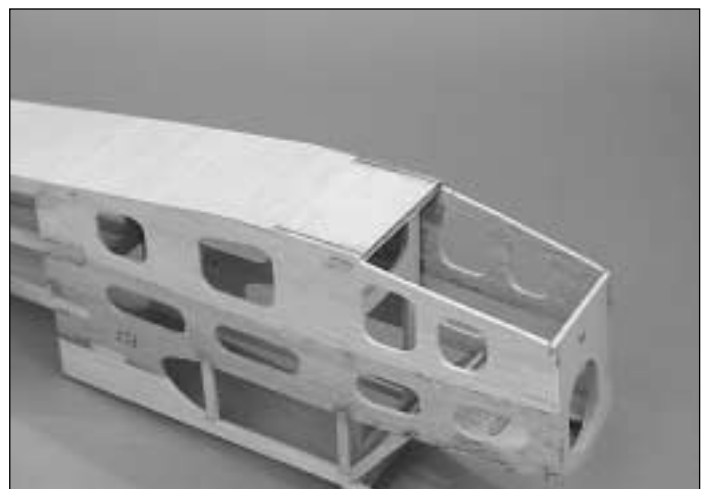

□ 32. Fit the 3/16" plywood **landing gear plate** between the fuse sides. Use 6-minute epoxy to glue the landing gear plate to the fuse sides and the bottom of former F-2.

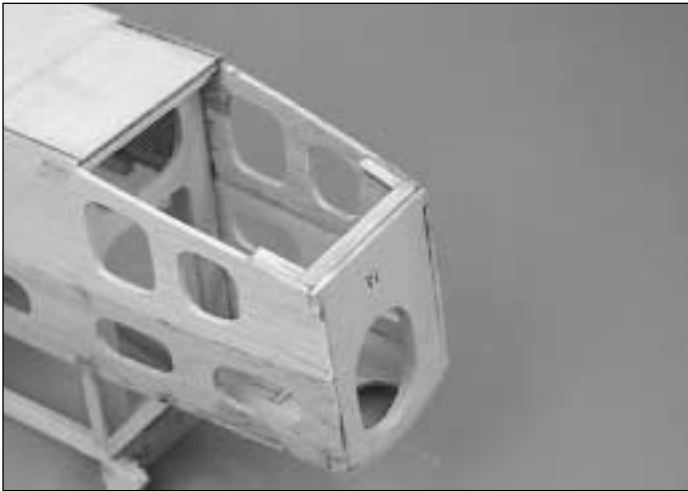

□ 33. From the 1/4" x 1/4" x 5-7/8" balsa triangle stick, cut and glue three pieces to fit in the lower front corner of the fuse. Sand the triangles flush with the bottom of the fuse.



□ 34. Glue the three die-cut 1/32" plywood **cowl screw backplates** to the inside of the fuselage sides and top front sheeting. See fuselage plan side view.



□ 35. From leftover 1/16" balsa (use a piece from a die-cut sheet), cut a 1/2" x 1-1/2" piece. Glue the piece to the aft end (wide end) of the die-cut 1/8" plywood **battery hatch**. Sand the aft end of the battery hatch to match the angle on the front of the landing gear plate.

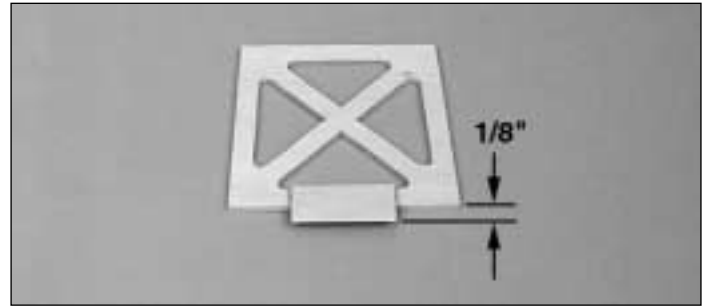

□ 36. Glue the die-cut 1/32" x 5/8" x 1-1/2" plywood **hatch plate** to the balsa strip on the aft end of the battery hatch. The hatch plate should extend about 1/8" past the aft edge.

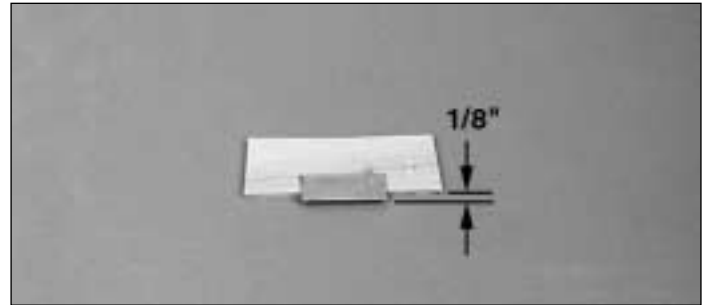

□ 37. Glue the die-cut 1/32" x 1/2" x 1-1/4" plywood **hatch stop** to the aft end of the die-cut 1/8" plywood **chin plate** so that it extends 1/8" behind the aft edge.

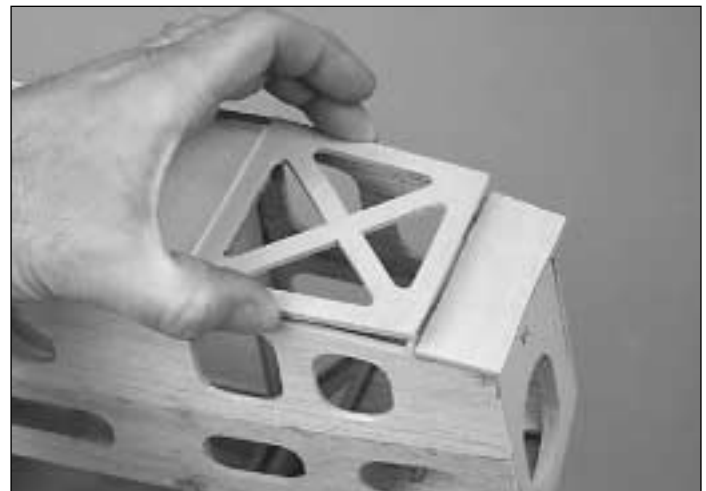

□ 38. Position the battery hatch and chin plate on the fuse, using the battery hatch as a spacer to determine the location for the chin plate. While holding the chin plate firmly in position, remove the battery hatch and apply thin CA around the chin plate to secure it in place.

DRILL 3/32"
HOLE



□ 39. From leftover 1/32" plywood, make the **hatch locking tab** as shown in the sketch.

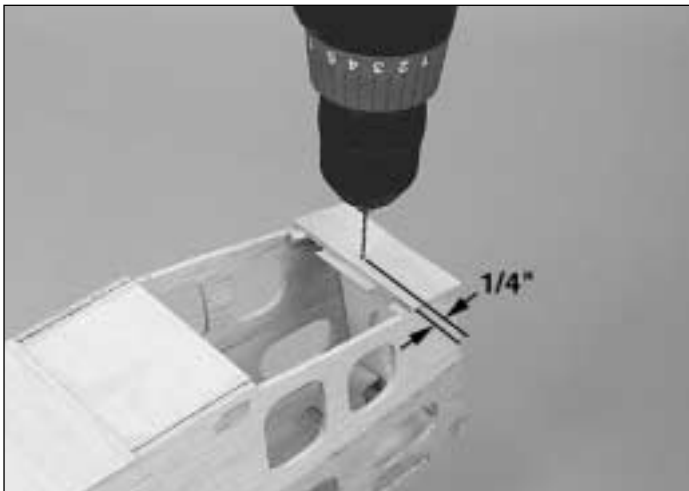

□ 40. Center the hatch locking tab on the aft edge of the chin plate. Mark the location of the screw hole on the chin plate and drill a 1/16" pilot hole.

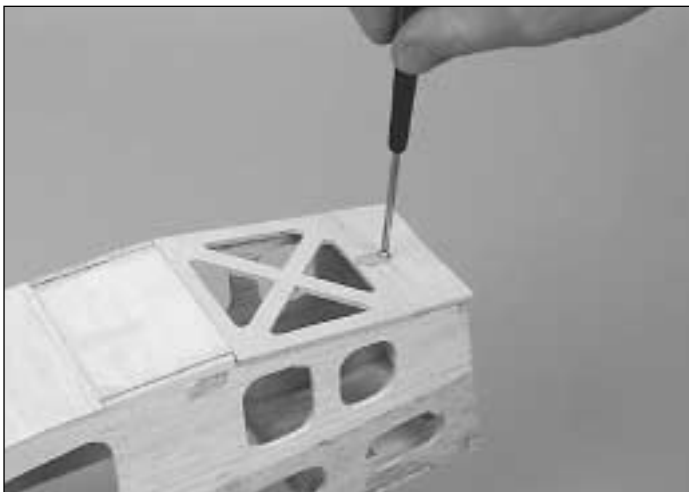

□ 41. Attach the hatch locking tab to the chin plate with a #2 washer and #2 x 3/8" sheet metal screw.

Note: The hatch locking tab is designed to keep the battery hatch closed during flight, yet it allows quick access to the front compartment for easy insertion and removal of the motor battery. **You must adjust the tab screw for sufficient friction so it will not allow the battery hatch to open during flight.** Periodically check and re-tighten the screw if necessary.



To reduce the weight of the wood structure, you can enlarge the lightening holes by 1/16" in the lower fuselage sides. A drum sander or a piece of sandpaper wrapped around a dowel makes quick work of it.



□ 42. Glue the die-cut 1/8" balsa **former F-3A** to the rear edges of the upper fuse sides and the aft deck base.

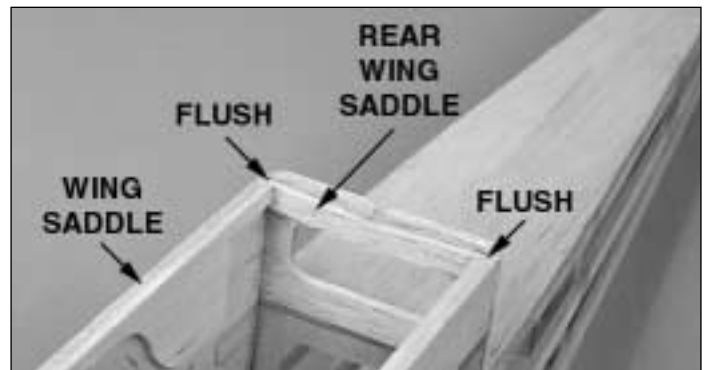

□ 43. Glue the die-cut 1/8" balsa **rear wing saddle** into the slots in the wing saddle doublers, flush with the top of the wing saddle.



□ 44. Use epoxy to glue the three die-cut 1/8" plywood **wing bolt plates** together. Use clamps to hold the plates together until the epoxy cures.



□ 45. Lightly sand the edges of the wing bolt plate to remove any excess epoxy. Test fit the wing bolt plate into the slots in the fuse sides, sanding as necessary to provide a good fit. When satisfied with the fit, use epoxy to glue the wing bolt plate to the fuse.

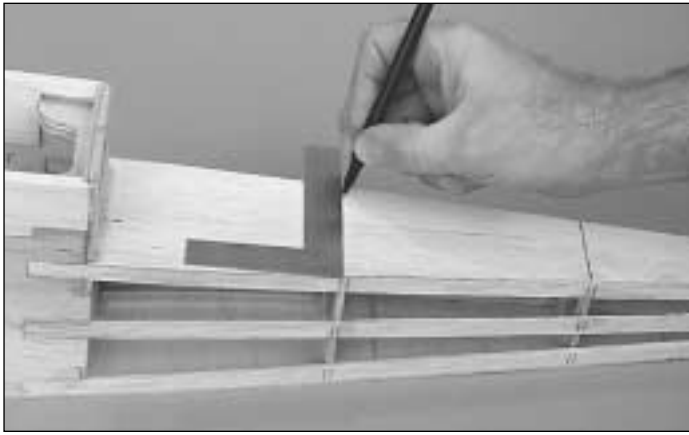

□ 46. Using the marks for formers F-4 and F-5 on the side of the longerons, draw lines across the top of the aft deck base.



To reduce the weight of the plane, you may cut large lightening holes in the aft deck base (between the formers). Leave approximately 3/8" of material along the sides and 3/4" near the formers.

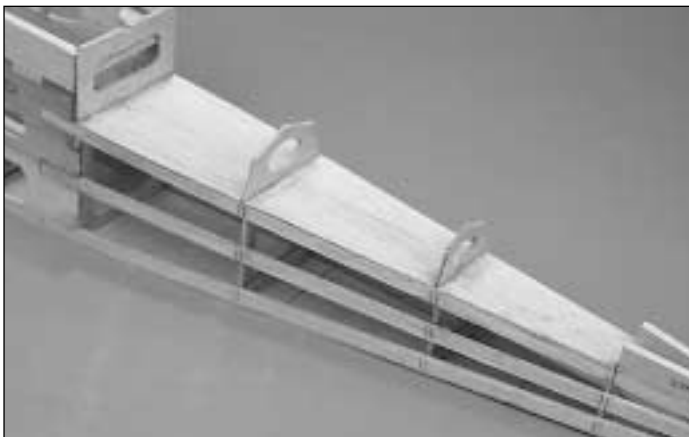

□ 47. Glue the die-cut 3/32" balsa **formers F-4A and F-5A** between the lines, perpendicular to the aft deck base.



□ 48. Glue the die-cut 3/32" balsa **former F-6A** to the front of the stab saddle and the aft deck base.

PUSHROD EXIT PLATE

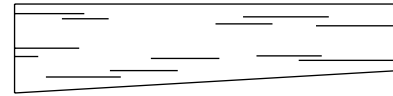

(ACTUAL SIZE)
1/8" Balsa

□ 49. From leftover 1/8" balsa (soft balsa preferred) cut two **pushrod exit plates** to the approximate shape as shown.

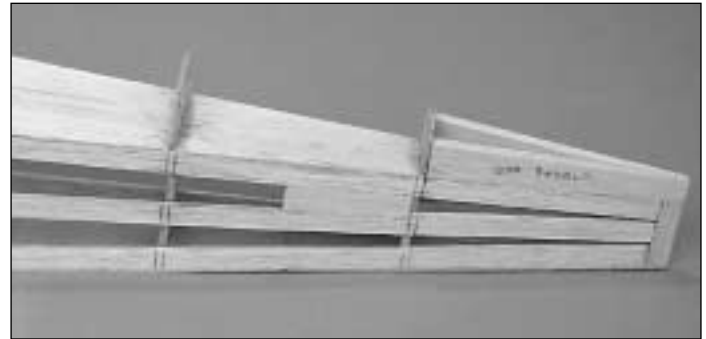

□ 50. Fit and glue the pushrod exit plates in front of former F-6, between the upper and middle longerons.

Sand the Fuselage

- 1. Fill any small gaps in the fuselage with balsa filler.
- 2. Use a sanding bar to sand the fuse sides and bottom smooth. Sand the top front sheeting and chin plate flush with the firewall.

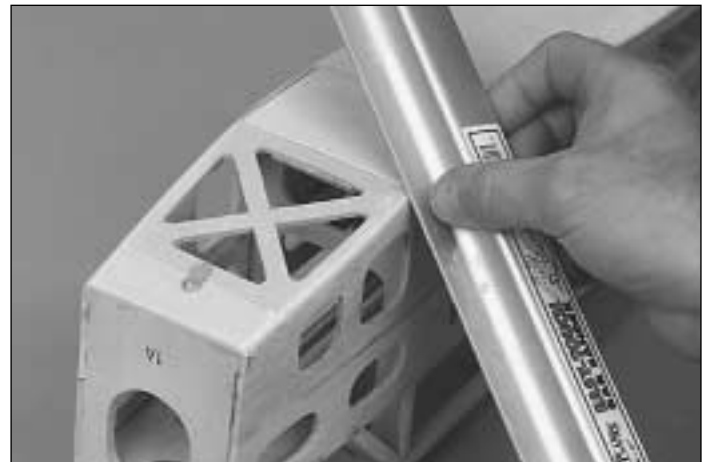

- 3. Sand the lower corners of the chin plate, battery hatch, landing gear plate and bottom sheeting to a slightly rounded shape as shown on the plan.
- 4. Lightly sand the front top sheeting to blend into the fuse sides.
- 5. Sand the wing saddle area slightly to remove any excess glue.

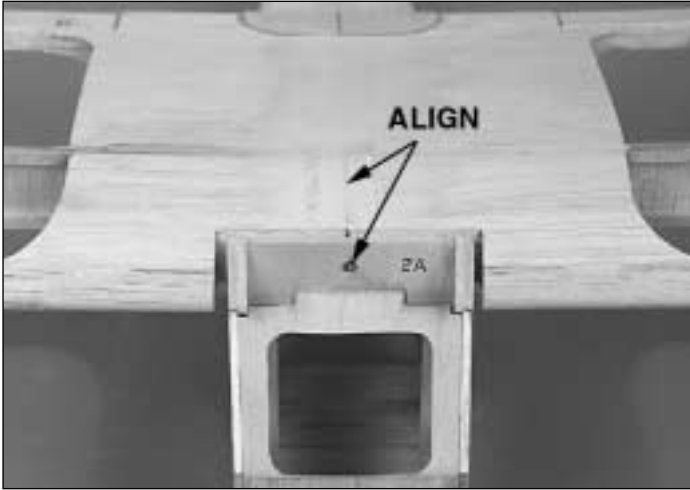

□ 1. Position the wing in the wing saddle and visually align it with the fuselage. The center joint of the wing should align with the hole in former F-2.

□ 2. Transfer the hole location onto the wing LE joiner and carefully cut out the hole to fit the 1/4" wing dowel.

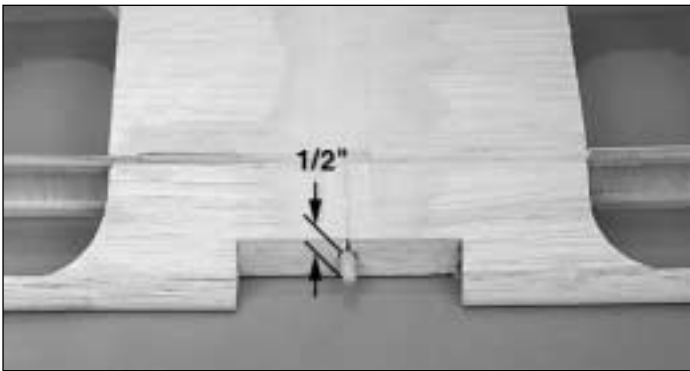

□ 3. Round both ends of the 1/4" x 1-1/2" **wing dowel**. Use epoxy to glue the wing dowel in the LE joiner and the slot in ribs W-1. Make sure the dowel is perpendicular to the LE joiner and protrudes 1/2" out of the forward wing joiner.



□ 4. After the epoxy cures, reinstall the wing on the fuse. Use epoxy to glue the die-cut 1/8" plywood **wing dowel doubler** to the front of former F-2. Before the epoxy cures, carefully remove the wing from the fuse.

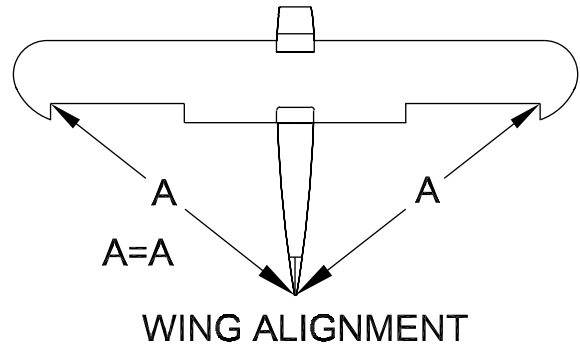

□ 5. Place the wing in the wing saddle and visually align it with the fuselage. Use a tape measure to measure the distance from the corner of the aileron bay to the center of the tail post. Then, measure the distance from the other aileron bay and check if the distances are the same. Adjust the wing until both distances are equal. When the wing is **perfectly aligned**, make reference marks on the wing trailing edge and former F-3A to help keep the parts aligned during the next step.

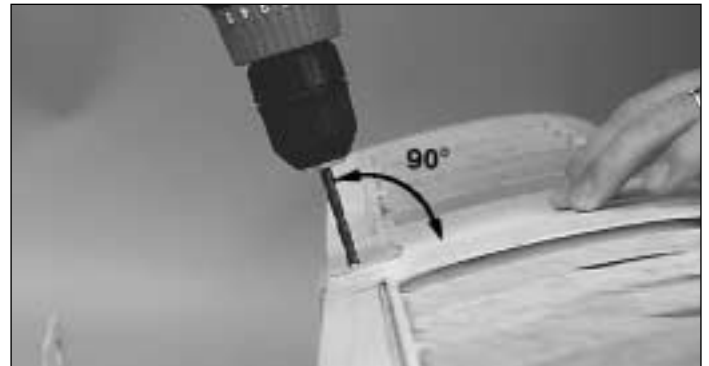

□ 6. Tape the wing in position so that it cannot move. Use a 5/32" (or #25) drill bit to drill a hole through the wing and wing bolt plate. Two small 90-degree triangles will help you to align the drill perpendicular to the top surface of the wing. **Important: Do not** allow the wing to shift during this procedure.

□ 7. Remove the wing and use a 13/64" drill bit to enlarge the holes in the **wing only**.



□ 8. Use a #10-24 tap to cut threads into the wing bolt plate. After cutting the threads, put a couple of drops of thin CA on

the threads in the wing bolt plate. After the CA has fully cured, thread the tap back through the holes to clean up the threads. Bolt the wing to the fuse with two nylon **10-24 wing bolts**, checking the fit.

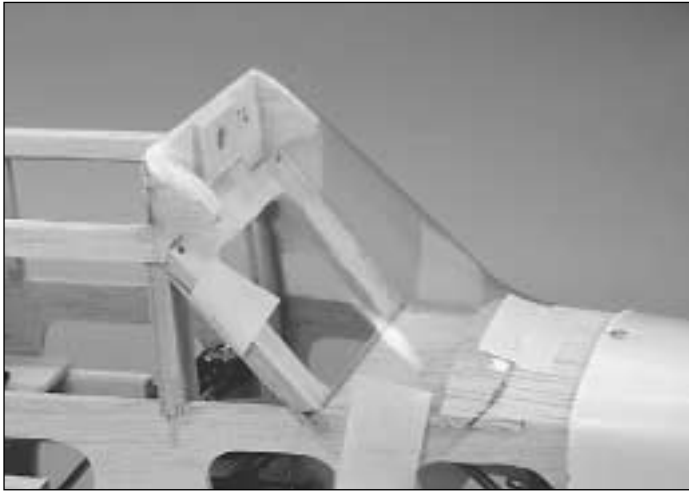

□ 9. Trim the clear **windshield** along the embossed “cut lines.” Then, tape it in position on the front of the cabin.



□ 10. With the wing installed, note the gap between the LE of the wing and the windshield. Install shims made from 1/16" balsa sheet to reduce the gap to 1/32" on each side.

Mount the Stabilizer & Fin

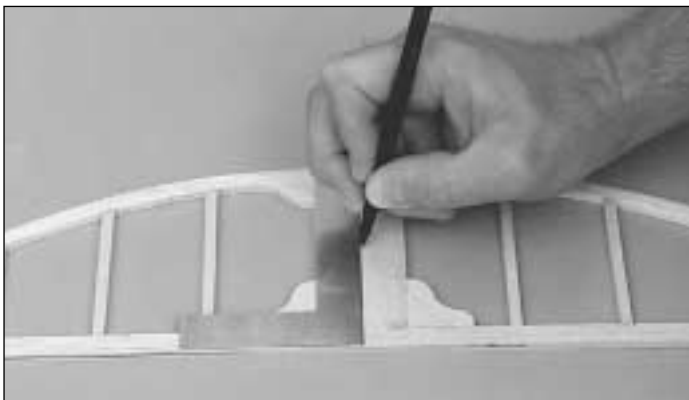

□ 1. To aid in alignment, draw an **accurate centerline** on the top of the stabilizer. This centerline should be in the middle of S-5 and perpendicular to the TE.

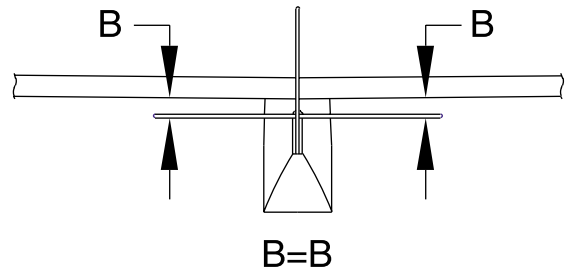
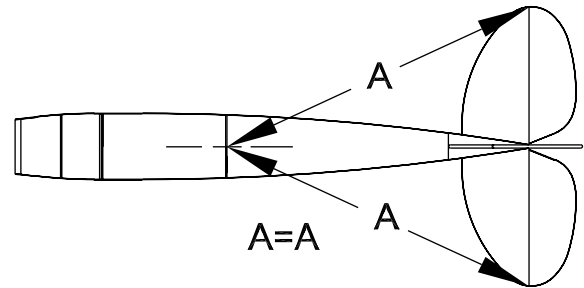

□ 2. Mount the wing on the fuse. Center the stabilizer on the stab saddle, aligning the centerline of the stab with the centerline of the fuse. From a few feet behind the fuselage, view the stabilizer, checking that the stabilizer is parallel with the wing. If not, remove the stabilizer and sand the saddle slightly. The front of the stab may need to be sanded slightly so that the stab TE is flush with the aft end of the fuse. When satisfied with the fit, use 30-minute epoxy to glue the stab to the fuse. **Double-check the stab alignment while the epoxy is curing.**

□ 3. Set the fin in position on the stab. The fin TE must line up with the aft edge of the fuselage tail post. If the fin is too far forward, sand V-1 slightly to allow the fin to slide back until the TE lines up properly. Also, the bottom of V-1 may need to be sanded to allow the fin to seat on the stab.

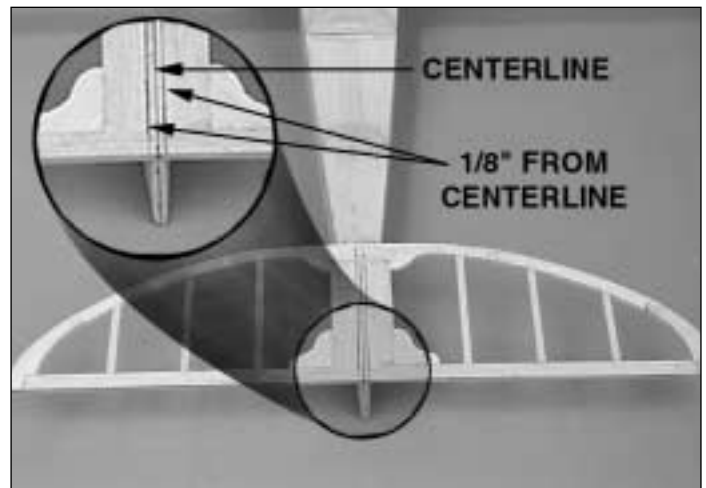

□ 4. Measure 1/8" on each side of the stab centerline and draw two lines parallel with the stab centerline.



□ 5. Set the fin in place, using the lines as a guide. Sight down the fin, checking that it is in line with the centerline of the fuselage. It is very important that the fin be aligned with the centerline of the fuse. If it is not, the plane will be difficult to trim. Use a square to check that the fin is perpendicular to the stab. Use 30-minute epoxy to glue the fin to the stab and aft deck base.

□ 6. You previously cut the hinge slots in the rudder and fin TE. Mark the location of the **bottom rudder hinge** on the fuselage tail post.

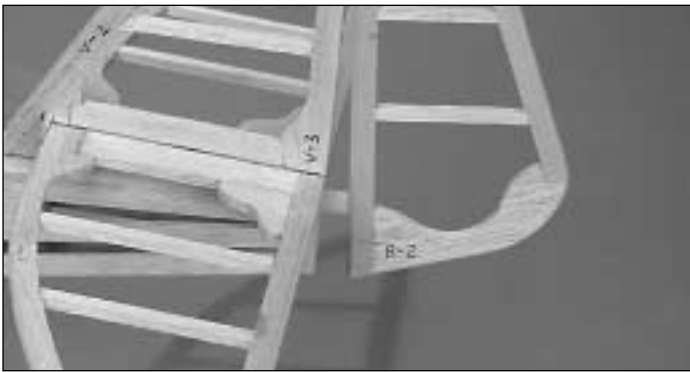

□ 7 Cut the hinge slot in the fuse tail post and trial fit the bottom rudder hinge in place.

Install the Dowel Stringers



□ 1. Position one of the 1/8" diameter **dowels** in the center notches of F-3A, F-4A, F-5A and F-6A. Sand the aft end of the dowel at an angle to match the angle of the fin LE. Glue the dowel in place. Then, cut off the forward end of the dowel flush with the front of F-3A.



□ 2. In a similar manner, cut and glue the other two 1/8" dowels in position.

Note: If you examine the fuse plan you will notice that there are 1/8" balsa filler pieces in the area in front of the fin. The purpose of these pieces is to make the fuse easier to cover and enhance the scale appearance.

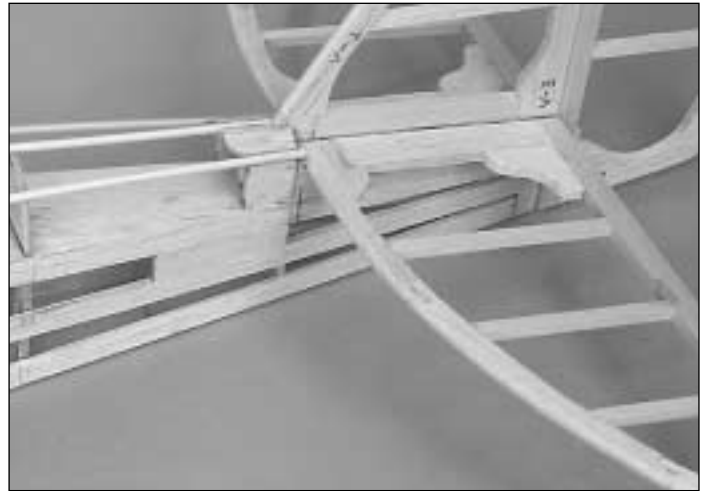

□ 3. Fit and glue the die-cut 1/8" balsa **filler pieces** between the dowel stringers and fin and the dowel stringers and aft deck base.

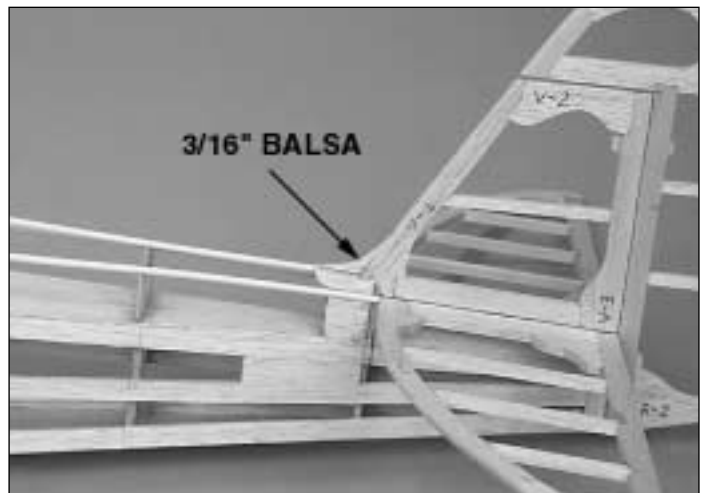

□ 4. From a leftover piece of 3/16" balsa, cut a piece to fit between the fin LE and the top dowel stringer. Glue it in place and sand the top edge to a rounded shape to match the fin LE.

1/8" X 3/8" BALSA STICK

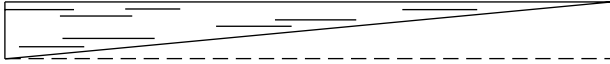

- 5. From a leftover 1/8" x 3/8" stick, cut a piece approximately 4-1/4" long to fit on the side of the fin, from former F-6A to the TE of the fin. Cut the piece in half diagonally to make two fairings.

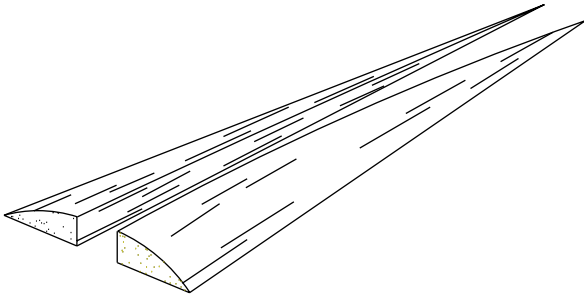

- 6. Sand the top surface of the fairings to a rounded shape.

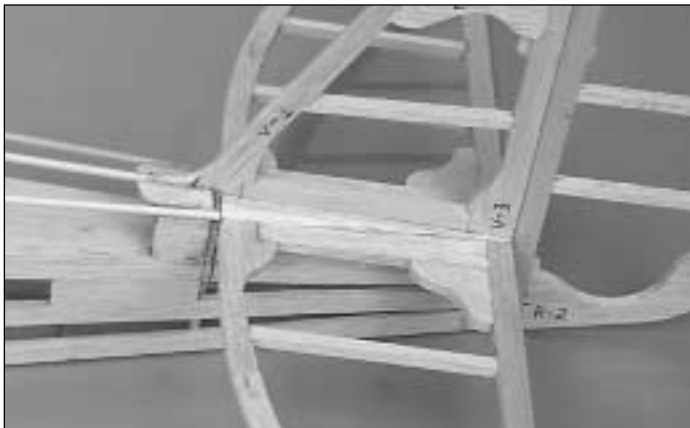

- 7. Test fit the fairings in place. The forward edge should be flush with the top of former F-6A. When satisfied with the fit, glue the fairings in place on both sides of the fin/stab joint.

- 8. Apply balsa filler to any gaps around F-6A to blend the fairings into the fin and stab.



- 9. From leftover 1/8" balsa, make gussets to fit at the joint between the outside dowel stringers and former F-3A.

Mount the Landing Gear

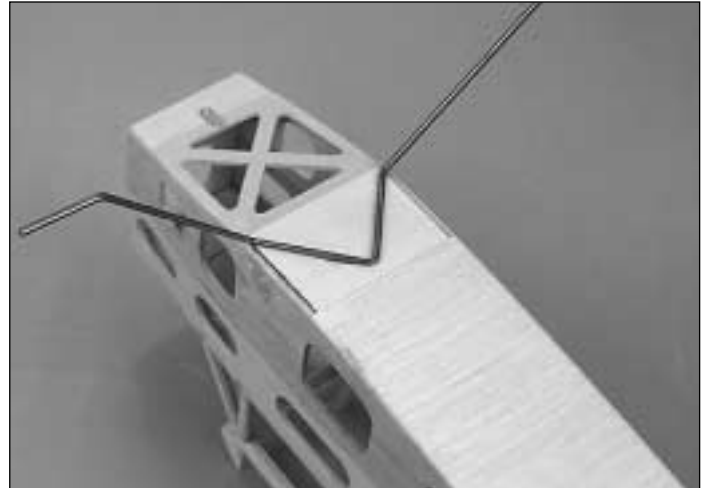

- 1. Turn the fuse upside-down and position the 1/8" wire **main landing gear** on the 3/16" ply landing gear plate as shown on the plan. Tack glue it in place with a drop of thin CA.
- 2. Position the three nylon **landing gear straps** over the main landing gear as shown on the plan. Mark the screw hole locations on the landing gear plate.
- 3. Drill a 1/16" diameter pilot hole at each location you marked.

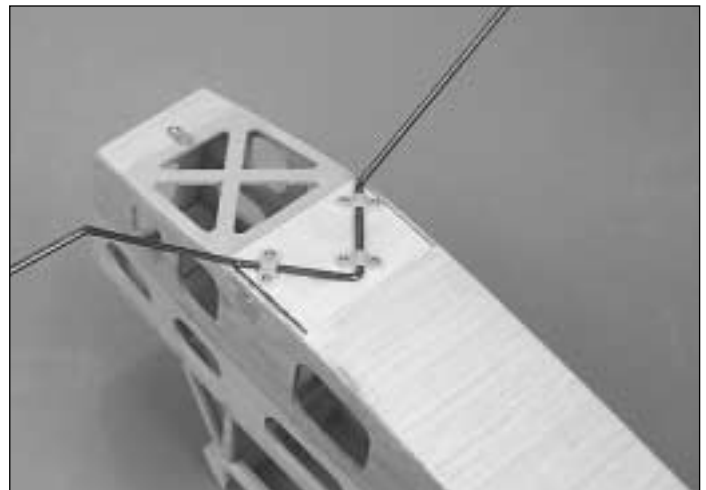

- 4. Temporarily secure the main landing gear to the landing gear plate with the landing gear straps and six #2 x 3/8" screws.



To reduce the weight of the plane, we recommend drilling several 1/4" diameter holes through the landing gear plate. Be careful to not drill through former F-2 or close to the landing gear straps.

- ❑ 5. On the LE of the rudder, drill a 1/16" hole, centered in the LE of the tailgear support, 3/8" from the bottom of the rudder.

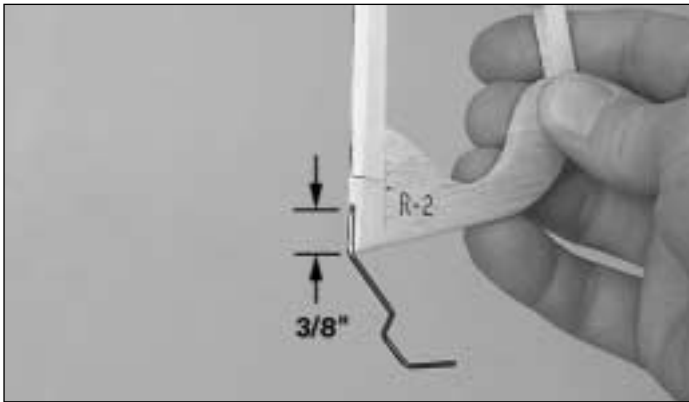

- ❑ 6. Use the threaded end of one of the threaded pushrod wires to file a small slot in the LE of the tailgear support for the 1/16" tailgear wire. Test fit the tailgear wire in the rudder. **Do not** glue it in place until after the rudder is covered.

Build the Motor Mount

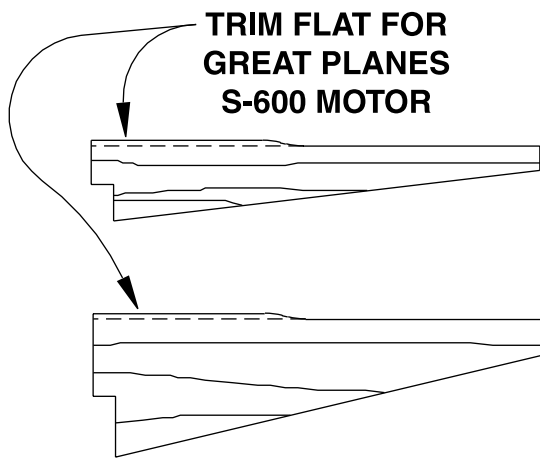

- ❑ **Important:** If you will be installing a motor with a diameter of 1-29/64" (such as a Great Planes S-600 motor with a flux ring) sand the raised area of the die-cut 1/8" plywood **motor mount sides** flat.

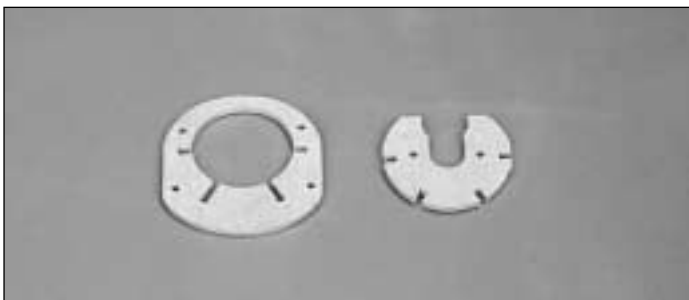

- ❑ 1. Drill a 1/8" hole at each of the punch marks on the die-cut 1/8" plywood **motor mount back** and **motor mount front**.

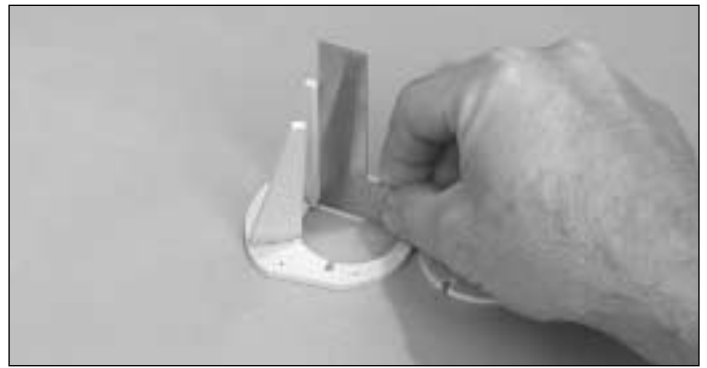

- ❑ 2. Glue the two **lower** motor mount sides perpendicular to the **motor mount back**.

- ❑ 3. Glue the two **upper** motor mount sides perpendicular to the motor mount back.

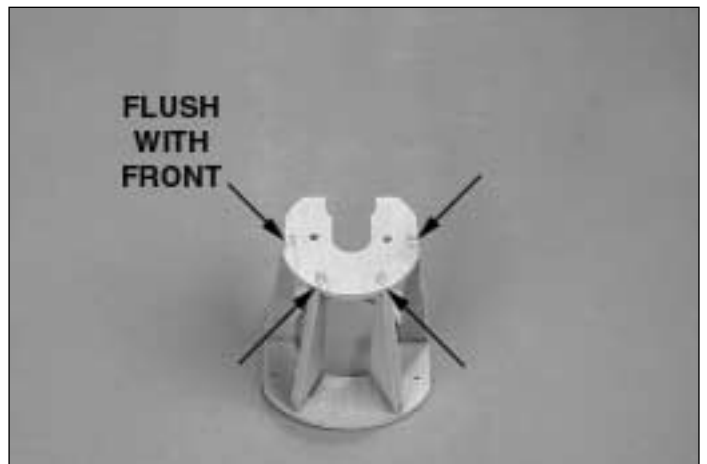

- ❑ 4. Glue the motor mount front, flush with the motor mount sides.

- ❑ 5. Use medium CA to reinforce all the glue joints on the motor mount.



- ❑ 6. If you will be using an S-600 direct drive motor, test fit the motor in the motor mount and secure it with two 3mm x 6mm machine screws and a rubber band at the rear.



□ 7. If you will be using a Great Planes T-600R Reverse Rotation motor with a Great Planes 2.5:1 gear drive, test fit the motor and gear drive in the motor mount and secure it with three rubber bands, two behind the gear drive and one at the back of the motor mount.

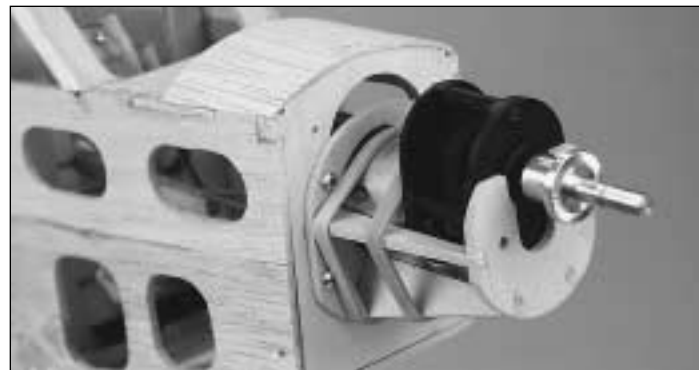
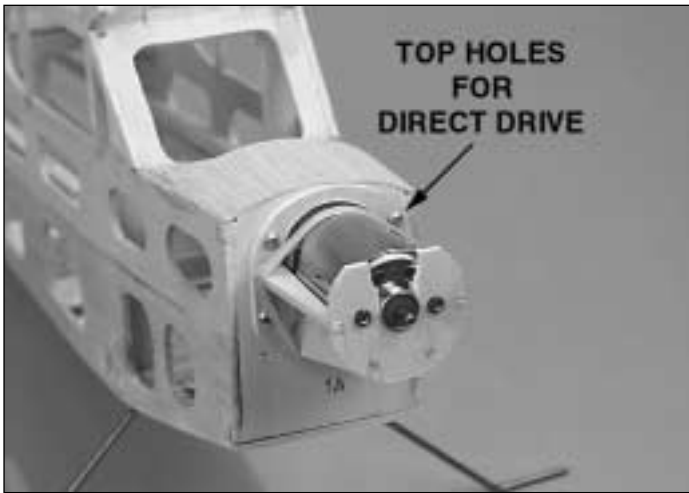

□ 8. Use four #4 x 1/2" sheet metal screws to temporarily attach the motor mount to the firewall. The direct drive setup is mounted in the top holes. The gear drive setup is mounted in the second set of holes, from the top.

Mount the Cowl



□ 1. Carefully trim the cowl along the mold seam at the back of the cowl. Use a hobby knife or Curved-Tip Canopy Scissors to cut out the propeller shaft hole and the vent holes in the front of the cowl. Also cut out the cooling air exit hole on the bottom of the cowl.

□ 2. There are three small indentations near the rear edge of the cowl, one on top and one on each side, toward the bottom. These are the mounting screw hole locations. Drill a 3/32" diameter hole at each location.

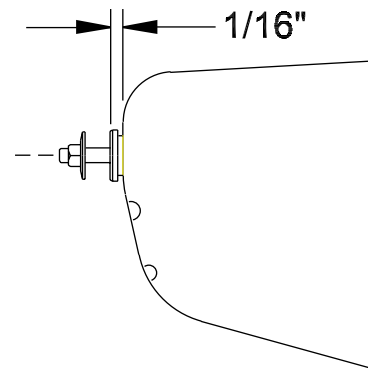

□ 3. With your electric motor mounted, slide the cowl into position. Make sure the propeller shaft is centered in the hole and there is approximately 1/16" clearance between the front of the prop adapter and the cowl. Mark the cowl screw hole locations on the fuselage.

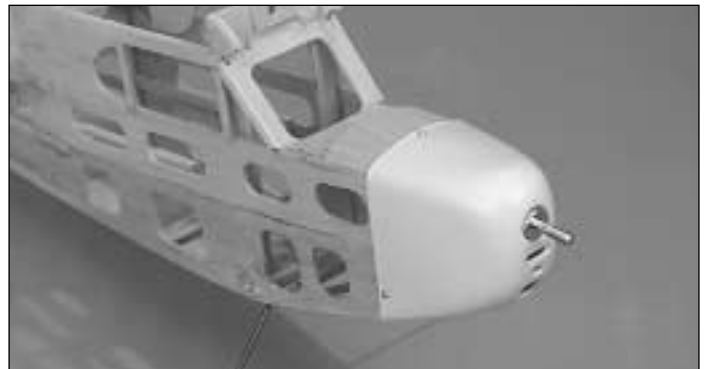

□ 4. Drill 1/16" diameter pilot holes in the fuse for the cowl screws. Temporarily mount the cowl to the fuse with #2 x 3/8" sheet metal screws. Do not over-tighten the screws.

□ 5. Cut out the dummy engines and exhaust pipes. Test fit them on the cowl. The cylinder heads should line up with the prop shaft of the real motor. Trim and sand as required for a good fit. We waited until after the cowl and dummy engines were painted before gluing them together.

□ 6. Since you are cutting out plastic parts, cut out the two hub caps also. Test fit them on your 2" main wheels (not included). When satisfied with their fit, set them aside until after they are painted.

Construct the Wing Struts

Note: The wing struts are **optional** (for scale like appearance) and are not required for flying. They do, however, add strength to the wing and do not seem to noticeably reduce the performance.

□ 1. Sand the **3/32" x 1/4" x 16-1/4"** hardwood sticks to an airfoil shape as shown on the wing plan.

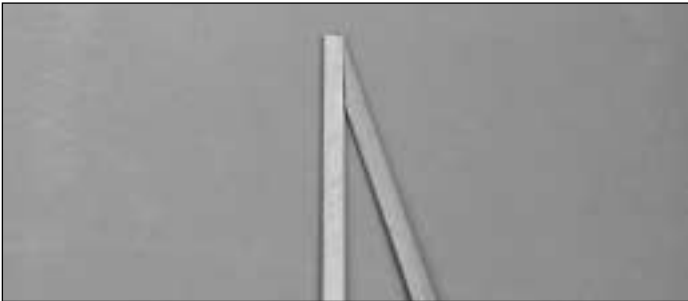

□ 2. Working over the wing strut drawing on the wing plan, make two sets of struts as shown. Note that where the struts join you must cut one of the struts off at an angle before gluing them together.

□ 3. Reinforce the ends of the struts by wrapping small pieces of **fiberglass** around the struts and applying CA glue. Sand the struts smooth.

□ 4. Drill 1/16" diameter pilot holes in the ends of the struts where shown for the mounting screws.

Note: The struts will be mounted to the wing and fuse after the plane is covered.

RADIO INSTALLATION

Mount the Servos

Note: The ElectriCub was designed to use mini servos on all control surfaces. If you are installing an electronic speed control, the throttle servo, receiver battery (if the speed control has BEC and auto cutoff) and the toggle switch can be omitted.

□ 1. Prepare the servos by installing the rubber grommets and brass eyelets into each servo.

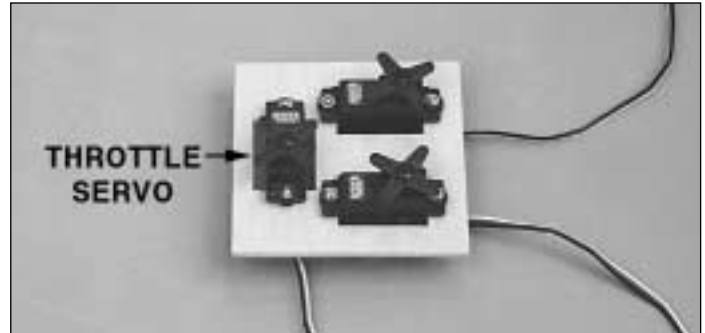

□ 2. Place the servos into the die-cut 1/8" plywood **servo tray** and position them so they do not touch the sides of the openings. Mark the servo mounting holes on the servo tray. Remove the servos and drill 1/16" pilot holes at the marks. Mount the servos to the servo tray using the mounting screws provided with the servos.



□ **Note:** If an electronic speed control is used, assemble the speed control tray and mount it in the top opening in former F-2A. The speed control can be held in place with a piece of Velcro® applied to the top of the tray and the bottom of the speed control.

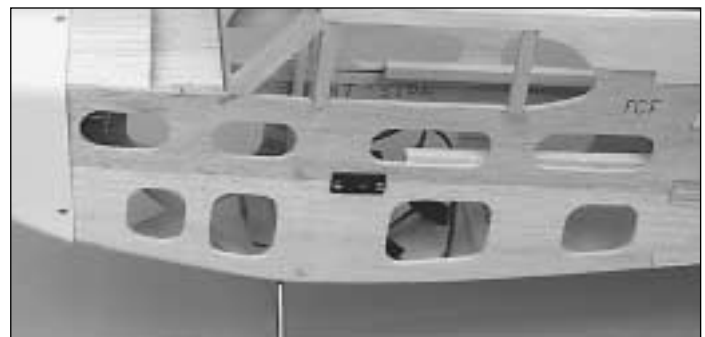

□ 3. Mount the receiver switch on the side of the fuse. We found a good place for the switch is just behind former F-2A along the joint between the bottom fuse side and middle fuse side.

❑ 4. Wrap the receiver and receiver battery (if used) in 1/4" foam rubber.

❑ 5. Temporarily position the receiver and receiver battery on the fuse bottom, in front of former F-3. Later, the receiver battery may be moved forward or aft to balance the plane. Plug the receiver battery into the receiver switch.

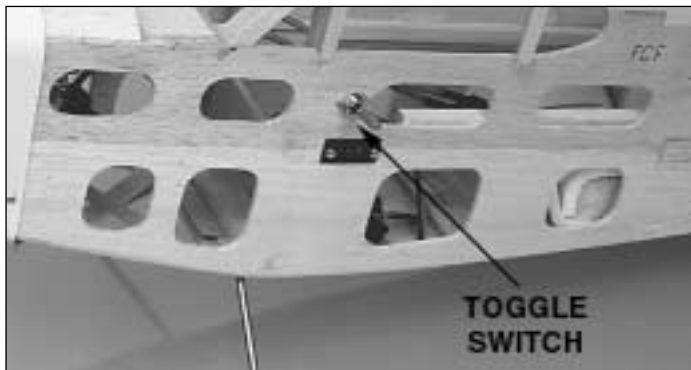

❑ 6. If you are installing one of the Great Planes motor packages with the switch harness, mount the toggle switch on the side of the fuselage.

❑ 7. Place the servo tray in the fuse. Do not attach it to the servo tray rails. It will be attached later, allowing it to be moved forward or aft to balance the plane. Plug the servos and receiver switch into the receiver.

❑ 8. Cut and sand one of the servo control wheels to a "cam" shape, similar to that shown on the plan. Clean the micro switch and the top of the throttle servo case with rubbing alcohol. Mount the micro switch to the top of the throttle servo case with double-sided foam tape in such a way that when you advance the transmitter throttle stick to full throttle (pushed towards the top of the transmitter), the servo wheel will activate the micro switch. When satisfied with the operation of the switch, secure the switch to the servo by wrapping with a narrow strip of strapping tape.

❑ 9. Charge the motor battery following the instructions included with your charger.

❑ 10. Make sure the propeller is removed before testing your motor system. Plug the motor battery into the switch harness and activate the toggle switch. The motor should begin running when the transmitter throttle stick is pushed forward to full throttle and stop when the stick is pulled back. With the toggle switch in the off position, you should **not** be able to start the motor with the throttle stick. **In order for this safety feature to be effective, you should always keep the toggle switch in the "off" position until you are ready to fly.**

NOTE: If you are using an electronic speed control, install it at this time following the instructions provided with the speed control. Test run the motor and speed control to make sure it operates properly.

❑ 11. Unplug and remove the motor battery from the plane.

Install the Nylon Control Horns

❑ 1. Separate the nylon control horns from the nut plates.



❑ 2. Lay the rudder on the fuse plan side view and determine the location for the nylon control horn. While holding one of the control horns in position on the **left side** of the rudder, mark the mounting hole location on the rudder.

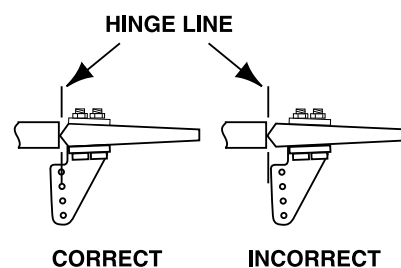

❑ 3. Drill a 3/32" diameter hole through the rudder at each mark.

❑ 4. Mount the control horn on the rudder with two 2-56 x 3/8" machine screws and the nylon nut plate.

❑ 5. Repeat the process to mount the control horn on the bottom right side of the elevator.

❑ 6. Reinstall the elevator on the stabilizer, but do not glue in the hinges.

❑ 7. Position the rudder on the fin and mark on the rudder the location of the elevator joiner wire. Cut a notch in the LE of the rudder to allow the elevator to move freely when the rudder is installed on the fin.

Make the Pushrods

❑ ❑ 1. Clean two of the 2-56 x 12" metal pushrods with rubbing alcohol and a paper towel to remove any oily protective coating.

❑ ❑ 2. Locate the two 1/4" x 1/4" x 13" balsa pushrod sticks set aside when building the wing. Mark one of them "rudder," the other "elevator."

❑ ❑ 3. Lay the elevator pushrod on the fuse top view. Note that the **front** pushrod wire attaches to the **top** of the balsa pushrod and the **rear** wire attaches to the **right side**. To avoid confusion later, draw lines 1-3/8" long on the pushrod where the wires will be attached.

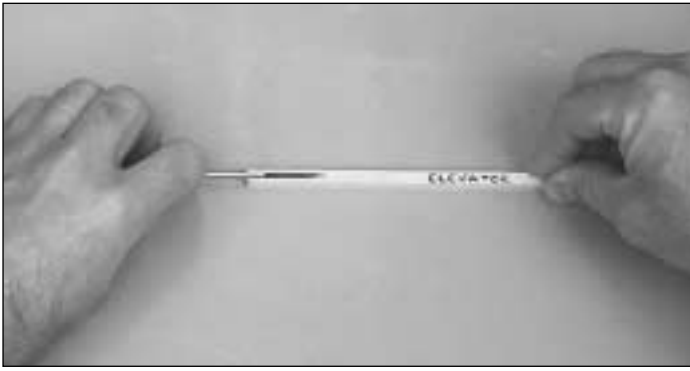

□ □ 4. Use the threaded end of one of the wire pushrods to “file” grooves in both ends of the pushrod where you drew the lines. The grooves need not be deeper than ½ the thickness of the wire.

□ □ 5. Drill 5/64" diameter holes through the pushrods 1-3/8" in from each end, at the end of the grooves you made in step 4.



□ □ 6. Bend one of the threaded wire pushrods to match the drawing of the elevator rear pushrod wire (top view). At the front end of this wire drawing, note that the wire makes a 90-degree bend and goes into the balsa pushrod. Make this bend and cut the excess wire off. **Do not** dispose of the excess wire.

□ □ 7. Use sandpaper to roughen the non-threaded end of the wire.



□ □ 8. Insert the wire into the hole and groove in the balsa pushrod. Apply a couple drops of thin CA to hold the wire in place.



□ □ 9. Sand the end of the pushrod to a rounded shape.

□ □ 10. Wrap kite string or strong thread (not included) around the wire and balsa pushrod. Then apply medium CA on the string.

□ □ 11. Make a 90-degree bend on one end of the leftover piece of wire pushrod cut off in step 6. Use sandpaper to roughen the end of the pushrod with the bend.

□ □ 12. Insert this rod into the hole and groove in the front end of the elevator pushrod, wrap with thread and apply thick CA.

□ □ 13. Repeat steps 1 to 12 to make the rudder pushrod. Notice that the groove in the front of this pushrod is on the **top** and the groove in the rear is on the **left** side.

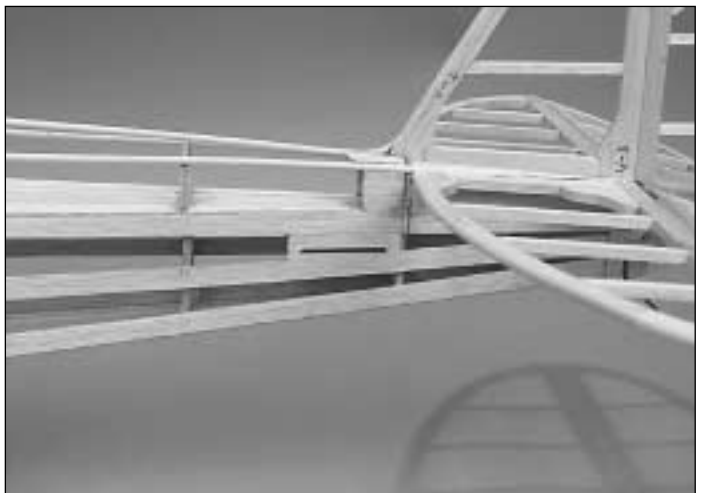

□ □ 14. Determine the location of the pushrod exit slots and mark them with a pencil. The elevator pushrod exit slot should be cut near the top of the right pushrod exit plate. The rudder pushrod exit slot should be cut near the bottom of the left pushrod exit plate. Drill 1/8" holes at the front and rear of the slot location. Then use a hobby knife to cut out the slot.

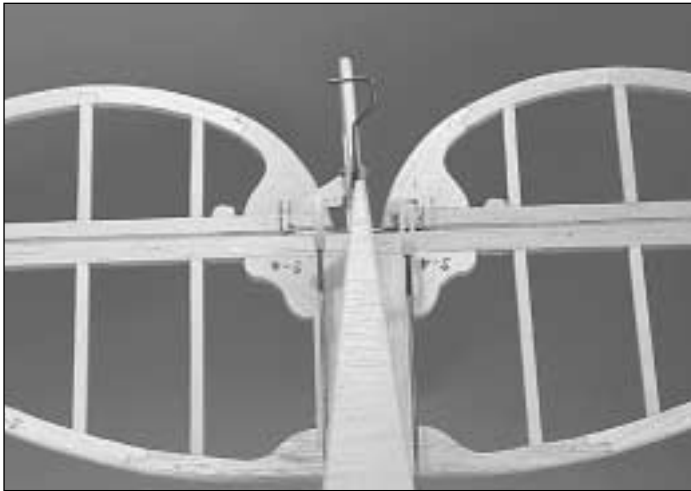

- 15. Temporarily install the elevator and rudder pushrods by inserting them through the hatch opening and out the pushrod exits. Install the clevises.
- 16. Operate the pushrods manually (with your fingers) and inspect the installation carefully, checking that the pushrods do not bind against each other or the formers.

BALANCE THE PLANE Laterally

SPECIAL NOTE: Do not confuse this procedure with “checking the C.G.” or “balancing the airplane fore and aft.” That very important step will be covered later in the manual.

Now that you have the basic airframe nearly completed, this is a good time to balance the airplane laterally (side-to-side). Here is how to do it.

- 1. Temporarily attach the wing and motor to the fuselage.
- 2. With the wing level, lift the model by the motor shaft and the bottom of the rudder (this may require two people). Do this several times.
- 3. If one wing tip consistently drops when you lift the plane, it means that side is heavy. Balance the airplane by gluing weight to the inside of the other wing tip.
Note: An airplane that has been laterally balanced will track better in loops and other maneuvers.

FINISHING

Final Sanding

Fill any scuffs and dings with balsa filler or by “expansion.” See Expert Tip below. After the filler has dried, use progressively finer grades of sandpaper to even and smooth all the edges, seams and surfaces. Remove all the balsa dust from the model with compressed air, a tack cloth or a vacuum with a brush.



Many surface blemishes on a framed model are caused by bumps and balsa chips on the work surface. This type of “ding” is best repaired by applying a drop or two of tap water to the blemish, then running a hot sealing iron over the spot to expand the wood fibers. After the surface has dried, sand the expanded area smooth.

Covering the Model

The ElectriCub does not require much painting to obtain the scheme shown on the box, as most of the finish is done with Top Flite® MonoKote® covering. The only painting required is the cowl, windshield frame, dummy engine and hubcaps.

The technique we will describe here is how the model pictured on the box was finished. Remove the motor, landing gear, windshield and control horns.

Cover the model with Top Flite MonoKote film, using the sequence that follows. The use of a Top Flite MonoKote Hot Sock™ on your covering iron will prevent scratching the MonoKote film.

Before you cover the fuselage, first apply 1/4" wide strips of MonoKote film in the corners where the stab and fin meet the fuselage. Proceed to cover the stab with pre-cut pieces that meet in the corners and overlap the 1/4" strips. **Do not, under any circumstances, attempt to cut the covering on the stab after it has been applied except around the leading and trailing edges and the tips.** Modelers who do this may cut through the covering and into the stab. This will weaken the structure to a point where it may fail during flight.

Some modelers prefer to cover the top and bottom of the ailerons with one strip of MonoKote film. This is done by covering the bottom first, then wrapping the MonoKote film up over the leading edge.

We used Top Flite MonoKote Cub Yellow (TOPQ0220) to cover our ElectriCub.

Suggested Covering Sequence

Fuselage and Tail:

1. 1/4" strips at fin and stab as described
2. Fin TE, followed by stab TE
3. Fuselage bottom
4. Fuselage right side
5. Fuselage left side
6. Fuselage top
7. Stab bottom, followed by top
8. Fin left side, followed by right side
9. Elevator LE
10. Elevator bottoms, followed by the top
11. Rudder LE, right side followed by the left side
12. Battery hatch cover (trim the covering from over the openings)
13. Landing gear fairing

Wing:

1. Trailing edges of wing
2. Bottom right, followed by the left wing panel
3. Top right, followed by the left wing panel
4. Aileron LE, followed by the bottom and top
5. Wing struts

Add Washout (Wing Twist)

An important characteristic of most airplanes is their ability to stall gently. One way to achieve this is with washout built into the wing. Washout is when the wing is twisted at the tips so that the TE of the wing is higher than the LE. This will cause the wing to first stall next to the fuselage, not at the tip. Because the ElectriCub is designed to be very light, washout would be difficult to build into the wing. The following procedure will explain how to put washout into the wing by shrinking the plastic covering. You will find that some coverings will stay tighter than others. Fabrics seem to relax slightly over time and may require re-shrinking more than once.

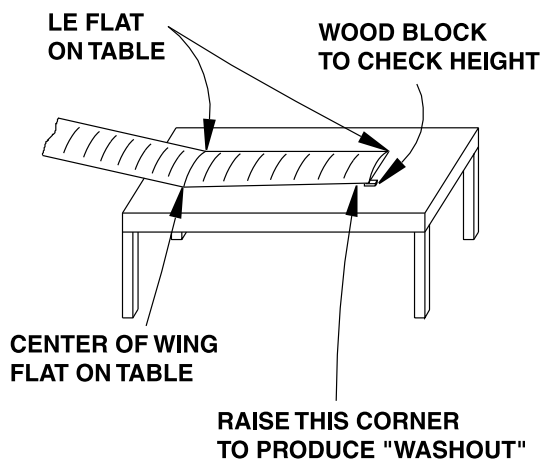

To put washout in the ElectriCub wing, have someone hold the center of the wing firmly down to the flat building surface. Now grasp the tip of the wing and twist it so that the

trailing edge raises off the surface. While holding in this twist, use a heat gun to "re-shrink" the covering. Heat both the top and the bottom. When you let go of the tip, you will see that the wing will retain some of the twist.

You must continue twisting and re-shrinking until the TE is 1/4" off the surface **at both tips**. As an aid in getting this height correct, you may make a small wood block 1/4" high by gluing together pieces of leftover wood. Keep this block handy while twisting and heating, to check your progress.

Depending on what type of covering you have used, you may find that, in time, some of the washout may disappear. Check it after an hour and repeat the above process if necessary. Also, recheck it periodically before you go flying.

Painting Your Model

Top Flite LustreKote® is a high quality paint that perfectly matches Top Flite MonoKote. The paint is well suited to putting a high quality finish on ABS (cowl and dummy engine), but does have a tendency to curl materials such as styrene and butyrate (windshield and side windows).

Do not paint the clear windshield with LustreKote directly from the can. It can cause the plastic to curl. We recommend Formula-U for painting the clear windshield directly from the can or the following procedure can be used for successful results with LustreKote.

The following procedure allows you to airbrush LustreKote with good results. The recommended procedure requires that the paint be sprayed into a jar or plastic mixing cup.

This is best done by spraying the paint through a small brass tube or straw into the jar. For best results spray no more than 1/2 oz. of paint into the jar at a time. As the propellant "boils off" it will cause the paint to foam slightly. Leave the paint in the open container, stirring every 15 minutes until no more foam appears on the surface of the paint and the paint has warmed to room temperature. This allows the propellant and some of the thinner to evaporate out of the paint. Depending on the amount of paint in the jar, this process may take about 1 hour.

After allowing the propellant to boil off, use an airbrush to spray paint the windshield. If the paint is too thick to spray properly, it can be thinned with a small amount of lacquer thinner. Do not thin with more than 40% thinner. In general, about 10% thinner will adequately thin the paint for airbrushing. The paint can also be brushed on, but brushing will not produce the high quality finish of spraying.

Allow the paint to dry overnight before gluing it on the plane. We recommend that the windshield be glued on within 48 hours of being painted.

If you have any doubt about the material you are painting, we suggest that you try painting on a small piece of leftover material and watch it for a few days to be sure that you are satisfied with the end results.

We used LustreKote Cub Yellow (TOPR7220) to paint the cowl, hubcaps and windshield. The dummy engine was sprayed with LustreKote Flat Black (TOPR7209). Then, after the paint dried, we brushed chrome paint on the valve covers. The inside of the fuselage was brushed with flat black in the cabin area.

FINAL HOOKUPS & CHECKS

Install the Hinges

- ❑ 1. Cut the covering from the hinge slots in the elevator and stab. Also cut the covering from the groove for the elevator joiner wire and the tailgear wire.
- ❑ 2. Clean the elevator joiner wire with alcohol and a paper towel to remove any oil residue.
- ❑ 3. Glue the joiner wire in the elevator halves with 6-minute epoxy. Before the epoxy cures, lay the elevator on a flat surface with a straightedge along the LE to keep it straight. Place weights on the elevator to keep it flat against the table until the epoxy cures.



INSTALLING CA HINGES

The hinge material supplied in this kit consists of a 3-layer lamination of mylar and polyester. It is specially made for the purpose of hinging model airplane control surfaces. Properly installed, this type of hinge provides the best combination of strength, durability and ease of installation. We trust even our best show models to these hinges, but it is essential to install them correctly. Please read the following instructions and follow them carefully to obtain the best results. These instructions may be used to effectively install any of the various brands of CA hinges.

The most common mistake made by modelers when installing this type of hinge is not applying a sufficient amount of glue to fully secure the hinge over its entire surface area; or, the hinge slots are very tight, restricting the flow of CA to the back of the hinges. This results in

hinges that are only "tack glued" approximately 1/8" to 1/4" into the hinge slots. The following technique has been developed to help ensure thorough and secure gluing.

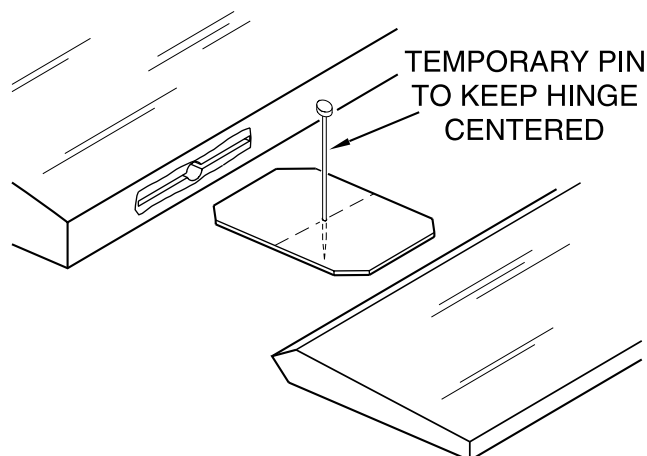

It is best to leave a very slight hinge gap, rather than closing it up tight, to help prevent the CA from wicking along the hinge line. Make sure the control surfaces will deflect to the recommended throws without binding. If you have cut your hinge slots too deep, the hinges may slide in too far, leaving only a small portion of the hinge in the control surface. To avoid this, you may insert a small pin through the center of each hinge before installing. This pin will keep the hinge centered while you install the control surfaces.

ASSEMBLE, THEN APPLY 6 DROPS OF THIN CA TO CENTER OF HINGE, ON BOTH SIDES

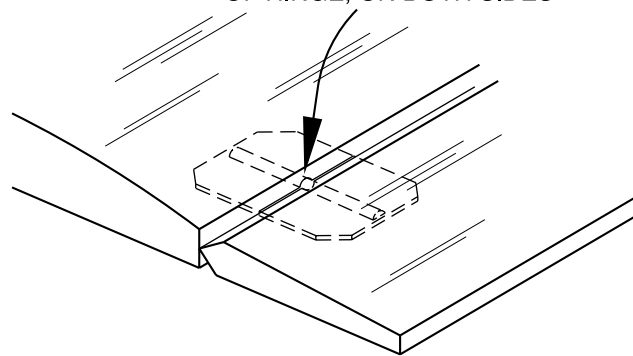

- ❑ 4. Apply 6 drops of thin CA adhesive to both sides of each hinge. Allow a few seconds between drops for the CA to wick into the slot. Use a paper towel to wipe off any excess CA that may have gotten onto the covering.
- ❑ 5. Install the ailerons with their hinges, repeating the gluing technique described previously.
- ❑ 6. Pack the tailwheel wire hole in the rudder with 6-minute epoxy. Install the rudder with its hinges. Repeat the gluing technique described previously and allow the epoxy to cure.

Install the Wheels

- ❑ 1. Install a 3/4" tail wheel (not included) on the tailgear wire. Secure the tail wheel with a 1/16" wheel collar (not included).



- ❑ 2. Reinstall the landing gear on the fuse. Install the 1/8" **wheel collars** (not included) against the inside bend of each landing gear wire and secure it with a set screw. Install the 2" main wheels (not included) and the other 1/8" wheel collars to secure the wheels to the landing gear. Place the wheel collars as close to the wheels as possible without interfering with the rotation.



- ❑ 3. Mark the landing gear at the outboard edge of the wheel collar. Remove the wheel collar and wheel. Cut off the excess landing gear wire to allow the hubcaps to be mounted to the wheel.
- ❑ 4. File or grind a flat spot where each wheel collar set screw contacts the landing gear wire.



- ❑ 5. Reinstall the wheels and wheel collars using thread locking compound on the set screws. Glue the hubcaps to the wheels with thick CA.

Install the Plastic Parts



- ❑ 1. Cut one of the #64 rubber bands into six pieces, each 5/8" long. Hold the landing gear fairing to the landing gear, pull the rubber band "straps" around the landing gear and glue them to the covering with thin CA. The forward rubber band straps go over the landing gear and the aft strap attaches to the fuse.

- ❑ 2. Reinstall the motor and cowl.

- ❑ 3. Glue the dummy engines on the cowl so the cylinder heads line up with the prop shaft.

- ❑ 4. Lightly sand a strip approximately 1/8" wide along the inside of the windshield (around the perimeter).

Note: To avoid sanding more than you want, it is helpful to first apply strips of masking tape on the inside of the windshield, 1/8" in from the edge.

- ❑ 5. Hold the windshield in place on the fuselage. Use a fine tip marker to trace the outline of the windshield onto the covering. Remove the windshield and use a sharp #11 blade to cut the covering just inside the line you drew. A sharp blade is important so you do not have to use much pressure. It will allow you to cut only the covering and not the underlying wood.

- ❑ 6. Carefully glue the windshield in place with a "canopy glue," such as Pacer Formula 560 Canopy Glue. We do not recommend CA, as it may fog the plastic. Use masking tape to hold it in place while the glue dries.

- ❑ 7. The side windows are cut from the 5" x 6" butyrate sheet. Use the template on the fuse plan as a guide to trim the windows to fit along the inside of the cabin side. After the windows have been trimmed to fit, glue them in place with a glue compatible with butyrate. Note that the front and rear side windows are left open for cooling air to exit.

❑ 8. The ElectriCub kit contains a decal sheet including the small emblems which would be difficult to reproduce otherwise. These decals are the “peel-and-stick” type. Cut around the individual decal emblems, peel off the protective backing and apply them to your airplane.

❑ 9. The large wing numbers and lightning bolts (for the side of the fuse) are not provided in decal form; therefore, you may cut these out of covering film or trim sheet material using the outlines shown on the plan.

❑ 5. Peel the backing from one of the fuzzy strips and press it firmly in place on the end of your motor battery.



Install the Motor Battery

❑ 1. The ElectriCub comes with two 3-1/2" long strips of Velcro® Brand Touch Fastener material, which have a sticky backing. One of the strips has a fuzzy texture and the other consists of hundreds of tiny plastic hooks. Cut each strip in half to make pieces 1-3/4" long.

❑ 2. Use a vacuum cleaner or a brush to remove all traces of sanding dust from the front surface of the **battery bench back** and the bottom of the F-2 opening.

❑ 3. Apply a few drops of medium or thick CA to the front surface of the battery bench back and the bottom of the F-2 opening. Spread the CA out to a thin layer, using a stick or your finger covered with plastic wrap. Allow the CA to cure. This will give the Velcro a better surface to adhere to.

❑ 6. Remove the battery hatch and slide the motor battery through the F-2 opening and into place against the hook strip on the battery bench back. With the battery in position, mark on the battery the location of where the battery is resting on the hook strip in the F-2 opening.

❑ 7. Remove the battery and apply the second fuzzy strip to the battery where you made the marks.

❑ 8. To use this system of securing the battery, turn the fuselage upside-down, remove the hatch, insert the battery until you feel it make contact with the battery bench, then raise the front of the battery until the Velcro engages. To remove the battery, **do not try to pull it straight out**. Instead, push down on the front of the battery to separate the front Velcro, then pull straight forward, separating the rear Velcro.

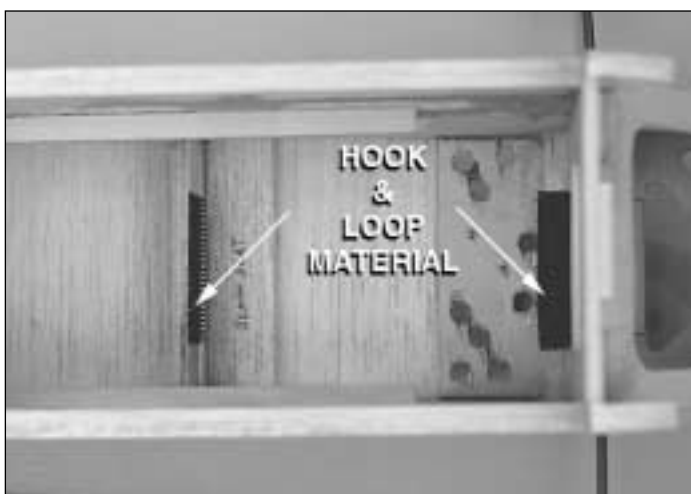

❑ 4. Peel the protective backing from one of the **hook strips** and press it firmly in place on the front surface of the battery bench back. Install the second hook strip on the bottom of the F-2 opening (on top of the 1/4" x 1/4" balsa cross braces).

Reinstall the Radio System

❑ 1. Reinstall the rudder and elevator control horns, pushrods, clevises, receiver, receiver battery, servo tray with servos, receiver switch and toggle switch.

❑ 2. Route the receiver antenna out the side of the fuse just under the TE of the wing. Anchor the antenna to the top of the fin with a rubber band and T-pin.

Note: Do not shorten the antenna! Leave any excess trailing behind the model.

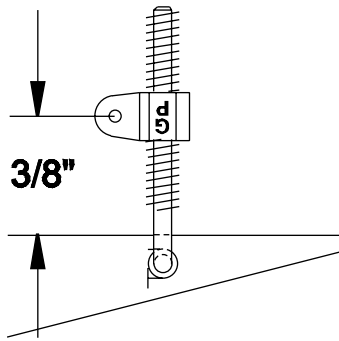

- 3. Install the aileron servo by first threading two nylon torque rod horns on the aileron torque rods so that they are approximately 3/8" above the bottom of the wing.

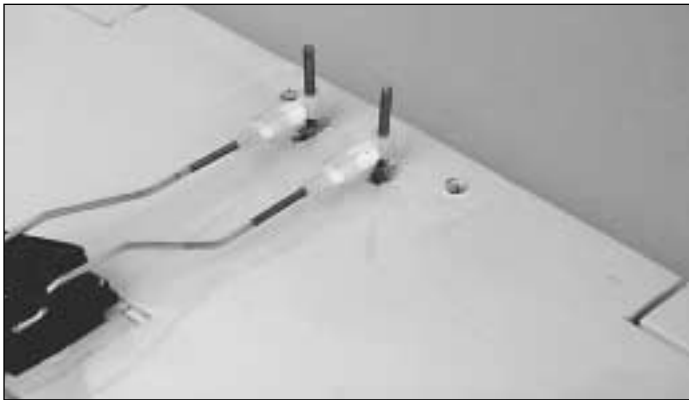

- 4. Thread two nylon clevises 14 turns onto the threaded end of two 12" wire pushrods. Connect the clevises to the torque rod horns and slide a silicone clevis retainer over each clevis.

- 5. Install a mini servo in the aileron tray and plug it into the receiver.

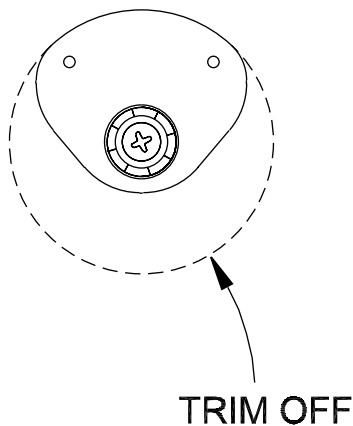

- 6. Trim a servo wheel as shown for aileron differential throw.

Aileron Differential Throw: Ailerons that are set up to deflect more in the upward direction than downward are said to have "Differential Throw." The purpose is to counteract "Adverse Yaw."

Adverse Yaw: The tendency of an airplane to yaw in the opposite direction of the roll. For instance, when right aileron is applied, the airplane yaws to the left, thus opposing the turn. Adverse yaw is common in trainer type airplanes having flat-bottom wings and is most noticeable at slow speeds and high angles of attack, such as during takeoffs and when stretching a landing approach. Caused by the unequal drag of the upward and downward deflecting ailerons, this undesirable trait can be minimized by setting up the ailerons with "Differential Throw," or by "coordinating" the turns, using aileron and rudder control simultaneously.

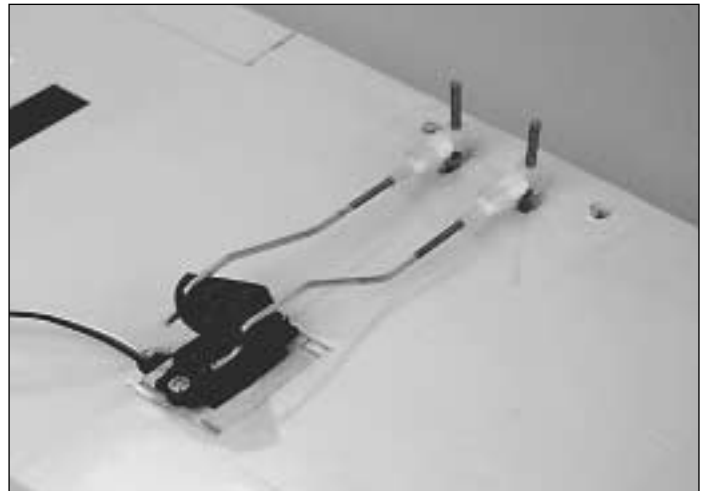

- 7. Bend the aileron pushrods as shown on the plan. Switch on the transmitter, then receiver. With the aileron servo centered, hold the aileron pushrods on the servo wheel and mark the hole locations on the pushrods. Make a Z-bend at the marks and insert the Z-bend in the servo wheel.

BALANCE YOUR MODEL

Note: This section is VERY important and must NOT be omitted! A model that is not properly balanced will be unstable and possibly unflyable.

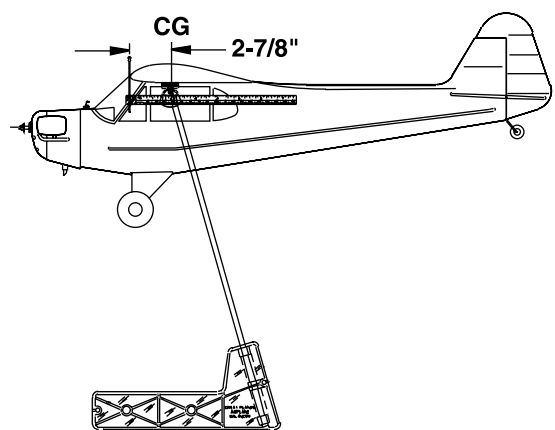

- 1. Accurately mark the balance point on the bottom of the wing on both sides of the fuselage. The **balance point**

(C.G.) is shown on the fuse plan and is located **2-7/8" back from the leading edge** of the wing. This is the balance point at which your model should balance for your first flights. After initial trim flights and when you become more acquainted with your *ElectriCub*, you may wish to experiment by shifting the balance up to **5/16" forward** or **backward** to change its flying characteristics. Moving the balance **forward** may improve the smoothness and stability, but the model may then require more speed for takeoff and may become more difficult to slow down for landing. Moving the balance **aft** makes the model more agile with a lighter, snappier "feel." In any case, **please start at the location we recommend. Do not at any time balance your model outside the recommended range.**

□ 2. With all parts of the model installed (ready to fly) and the motor battery installed, lift the model at the balance point. If the tail drops, the model is "tail heavy" and you must move the servo tray and possibly the receiver battery forward to balance the model. If the nose drops, it is "nose heavy" and you must move the servo tray and possibly the receiver battery toward the tail to balance the model. Because excess weight is critical to the flight performance of electrics, it is best to try balancing the plane by moving the servos and/or the receiver battery.

If you are unable to obtain good balance by moving the servos and receiver battery, then it will be necessary to add weight to the nose or tail to achieve the proper balance point.

□ 3. After the plane is properly balanced, use four #2 x 3/8" sheet metal screws to secure the servo tray to the servo tray rails.



EXPERT TIP
EXPERT TIP

To reduce the weight of the plane, you may trim the length of the servo tray rails flush with the edge of the servo tray.

FINISH THE RADIO INSTALLATION

□ 1. Switch on your transmitter, then the receiver. Center the elevator and rudder servos. Be sure the trim levers on your transmitter are centered.

□ 2. Center the elevator. Then, mark the pushrod where it crosses the middle servo horn hole. Enlarge the servo horn hole with a 5/64" diameter drill bit.

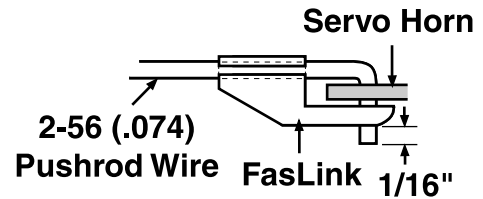

□ 3. Make a 90-degree bend in the pushrod on your mark, then insert it through the enlarged hole in the servo horn. Secure it with a nylon **FasLink™**.

□ 4. Repeat steps 2 and 3 for the rudder.

□ 5. Check that the throttle servo is properly switching the micro switch on and off. **Caution:** Make sure the toggle switch is off and the motor battery is unplugged.

INSTALL THE WING STRUTS

Important: Before installing the wing struts make sure that the wing washout is correct.

□ 1. Reinstall the wing on the fuse. Turn the wing and fuse upside-down in an airplane cradle or on a thick piece of foam. It must be supported near the center in such a way that it does not change the washout angle of the wing tips.

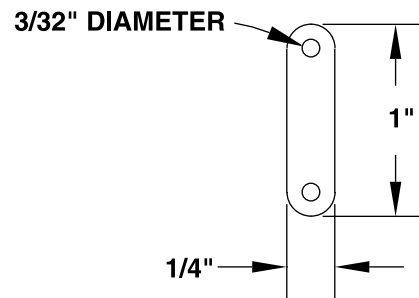

□ 2. Make six 1/4" wide **wing strut straps** from the 4" nylon strip material (not the CA hinge material).

□ 3. Attach the wing strut straps to the ends of the wing struts with #2 x 3/8" sheet metal screws.

Note: Refer to the detail drawing on the wing plan which shows how the straps are mounted to the struts. Cut off the excess portion of the screws.

□ 4. Refer to the top view of the fuse plan for the location of the die-cut 1/16" plywood **strut backup plates**. Glue the backup plates on the inside of the fuse bottom.

□ 5. Drill 1/16" pilot holes in the fuse bottom through the strut backup plate.

□ 6. Attach the struts to the fuse with #2 x 3/8" sheet metal screws.

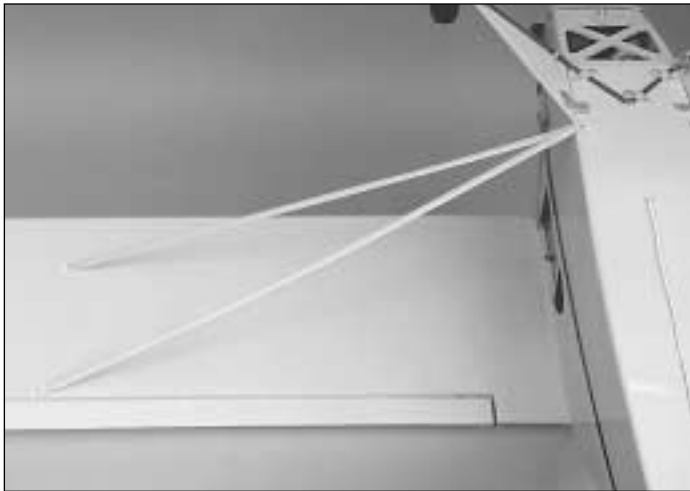

□ 7. Hold the ends of the struts in place on the strut plates in the wing and mark the location of the screw holes. Drill 1/16" pilot holes at these locations and attach the strut ends with #2 x 3/8" screws.

Caution: If you thread the rear strut mounting screws in all the way, they will puncture the covering on top of the wing. Therefore, you should only turn the rear screws in a couple of turns to create a thread pattern in the holes. Then, remove the screws and cut off about half of the threaded portion and reinstall the screws.

Note: You may leave the struts permanently attached to the wing. When you remove the wing from the fuse, just remove the two screws which attach the struts to the fuse. For storage the struts may be folded down onto the wing and held in place with a rubber band.

SET THE CONTROL THROWS

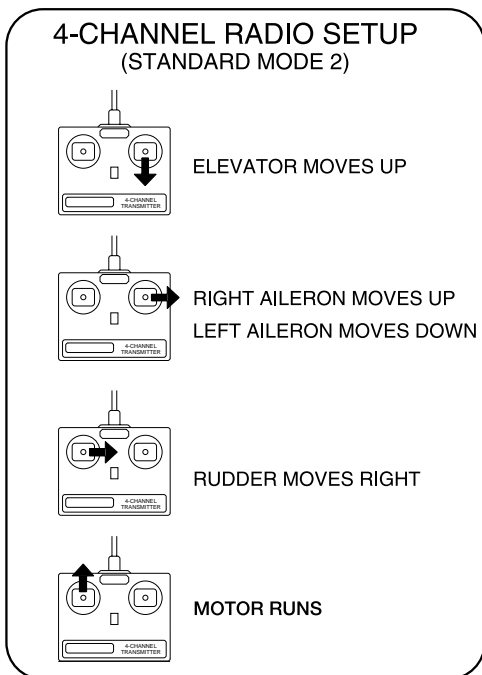

The throws are measured at the widest part of the elevators, rudder and ailerons. Adjust the position of the pushrods at the servo horns and the nylon control horns to change the amount of throw. You may also use the ATV's if your transmitter has them.

We recommend the following control surface throws:

	High rate	Low rate
Elevator	3/4" up 3/4" down	5/8" up 5/8" down
Rudder	3/4" left & right	1/2" left & right
Ailerons	1/2" up 3/8" down	3/8" up 1/4" down

Note: If your radio does not have dual rates, we recommend setting the throws between the low and high rate amount.

Important: The balance and control throws for the ElectriCub have been extensively tested. This chart indicates the settings at which the ElectriCub flies best. Please set up your model to the specifications listed above. If, after you become comfortable with your ElectriCub, you would like to adjust the throws to suit your tastes, that's fine. Too much throw can make the plane harder to handle or force it into a stall or snap roll, so remember, "more is not always better."

PROPER CARE OF YOUR MOTOR

1. The recommended Great Planes S-600 motor for direct drive and T-600r motor for gear drive require "Break-in" by running the motor without the propeller for at least 1/2 hour. This will seat the motor brushes on the commutator, insuring that the motor will provide full power for your first flight and extend the life of your motor. If you notice a decrease in motor power after several flights, it may be due to carbon build-up on the brushes or commutator. To remove this build-up, repeat the above break-in procedure.

2. The bronze bushings in the motors are self lubricating, but their life may be extended by applying a very small amount of light machine oil to the point where the motor shaft contacts the bushings after every hour or two of run time. **Note:** A drop of oil is far too much. You should apply the oil with a toothpick. **Never oil the inside of the motor.**

3. Using multiple battery packs to run the motor in successive flights may cause the motor to become excessively hot. We recommend at least a 10-minute cool-down period between flights.

4. If the propeller should become stalled, such as running into long grass or by nosing over, the motor will draw excessive current, causing the fuse to blow (the internal

fuse wire melts). If the fuse blows, turn off the toggle switch, disconnect the battery and check the condition of the wires, replacing any that are damaged. Replace the fuse with a fuse rated no higher than 25 amps. Never operate the system without a fuse. Doing so could result in a fire, causing property damage and personal injury.

5. The ideal power source for the S-600 direct drive system is a 7-cell, 8.4 volt 1700 - 2000 mAh battery pack. The use of a higher voltage battery may reduce the motor life. The ideal power source for the T-600GD gear drive system is a 7-cell, 8.4 volt 1700 - 2000 mAh battery pack, but an 8-cell, 9.6 volt battery pack will also work well.

6. We have done extensive motor/propeller testing and have found that the 8 x 4 prop included with the S-600 motor system works well, providing 4-5 minutes of flight time.

With the T-600GD gear drive system we found that the Master Airscrew 10 x 8 electric prop provided 6-8 minutes of very good flight performance.

PERFORMANCE TIPS

1. A new battery pack should be "cycled" for best results. You should peak charge the battery, then discharge it almost completely by actually running your motor with the propeller attached. Do this 3 or 4 times on the ground before actually flying. Be sure you remove the battery from the airplane between each cycle and allow it to cool before recharging.

2. The wires supplied with your motor/micro switch are long enough to allow the micro switch to be mounted on the servos for ease of installation. You may reduce the electrical resistance of the switch harness by shortening the wires, resulting in an increase in motor power. The micro switch can be mounted in front of former F-2A and operated by a pushrod from the throttle servo.

3. The switch harness wire can also be replaced with larger high performance 12 or 13 gauge wire. This type of wire is normally multi-strand (600 to 700 strands). The larger the wire, the less resistance in the wire.

4. The standard Tamiya battery connectors supplied with your switch harness are adequate for most installations. However, if you are looking for maximum performance, you may want to consider installing high-performance battery connectors such as DuraTrax® Powerpole™ connectors or Astro Flight Zero Loss connectors.

5. Examine your propeller for irregularities caused by the injection molding process. Carefully remove the imperfections with fine sandpaper. Also, make sure your propeller is balanced. Vibration from the propeller will decrease the performance and life of the motor.

6. If you are taking off from a hard surface, the wheels must spin freely. Check the wheels for binding when moved from side to side and put a drop of oil on each axle (including the tail wheel). If you store your ElectriCub resting on its wheels, the wheels may develop "flat spots," which prevent them from rolling smoothly. This can be a problem when using light weight foam wheels. To avoid this problem, store your airplane on an airplane stand or hanging from the ceiling.

PREFLIGHT

At this time check all connections including servo horn screws, clevises, servo cords and extensions. Make sure you have installed the silicone retainers on all the clevises.

Charge the Radio Batteries

Follow the battery charging procedures in your radio instruction manual. You should always charge your transmitter and receiver batteries the night before you go flying and at other times as recommended by the radio manufacturer.

Balance the Propeller

Carefully balance your propellers before flying. An unbalanced prop is the single most significant cause of vibration which may damage your radio receiver, battery and motor.

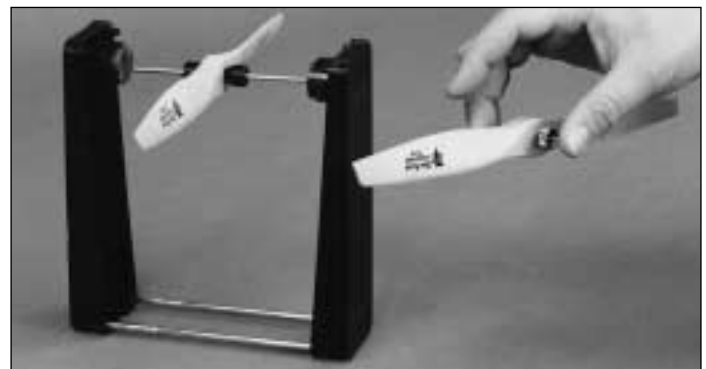

We use a Top Flite Precision Magnetic Prop Balancer™ (TOPQ5700) in the workshop and keep a Great Planes Fingertip Balancer (GPMQ5000) in our flight box.

Find a Safe Place to Fly

The best place to fly your ElectriCub is at an AMA chartered club field. Ask the AMA or your local hobby shop dealer if there is a club in your area and join. Club fields are set up for R/C flying and that makes your outing safer and more enjoyable. The AMA also can tell you the name of a club in your area. We recommend that you join AMA and a local club so you can have a safe place to fly and have insurance to cover you in case of a flying accident. The AMA address and telephone number are in the front of this manual.

If a club and flying site are not available, find a large, grassy area at least 6 miles away from houses, buildings and streets and any other R/C radio operation like R/C boats and R/C cars. A schoolyard may look inviting but is too close to people, power lines and possible radio interference.

Ground Check the Model

Inspect your radio installation and confirm that all the control surfaces respond correctly to the transmitter inputs. The motor operation must also be checked by confirming that the motor reaches full power and the prop is rotating in the correct direction. Make sure all screws remain tight, that the hinges are secure and that the prop is on tight.

Range Check Your Radio

Whenever you go to the flying field, check the operational range of the radio before the first flight of the day. First, make sure no one else is on your frequency (channel). With your transmitter on, you should be able to walk at least 100 feet away from the model and still have control. While you work the controls, have a helper stand by your model and tell you what the control surfaces are doing. Repeat this test with the motor running at various speeds with a helper holding the model. If the control surfaces are not always responding correctly, do not fly! Find and correct the problem first. Look for loose servo connections or corrosion, loose bolts that may cause vibration, a defective on/off switch, low battery voltage or a defective receiver battery, a damaged receiver antenna, or a receiver crystal that may have been damaged from a previous crash. If the radio appears to only be affected when the motor is running, try moving your receiver and receiver antenna farther away from the motor battery and motor. Also, installing a couple more capacitors on the motor may help. The capacitors should be soldered from the terminals to the motor case and from one terminal to the other.

AMA SAFETY CODE (excerpts)

Read and abide by the following Academy of Model Aeronautics Official Safety Code:

General

1. I will not fly my model aircraft in sanctioned events, air shows, or model flying demonstrations until it has been proven to be airworthy by having been previously successfully flight tested.
2. I will not fly my model aircraft higher than approximately 400 feet within 3 miles of an airport without notifying the airport operator. I will give right of way to and avoid flying in the proximity of full-scale aircraft. Where necessary an observer shall be used to supervise flying to avoid having models fly in the proximity of full-scale aircraft.
3. Where established, I will abide by the safety rules for the flying site I use and I will not willfully and deliberately fly my models in a careless, reckless and/or dangerous manner.
7. I will not fly my model unless it is identified with my name and address or AMA number, on or in the model.
9. I will not operate models with pyrotechnics (any device that explodes, burns, or propels a projectile or any kind).

Radio Control

1. I will have completed a successful radio equipment ground check before the first flight of a new or repaired model
2. I will not fly my model aircraft in the presence of spectators until I become a qualified flier, unless assisted by an experienced helper.
3. I will perform my initial turn after takeoff away from the pit or spectator areas and I will not thereafter fly over pit or spectator areas, unless beyond my control.
4. I will operate my model using only radio control frequencies currently allowed by the Federal Communications Commission.

FLYING

Caution (THIS APPLIES TO ALL R/C AIRPLANES): If, while flying, you notice any unusual sounds, such as a low-pitched "buzz," this may indicate control surface "flutter." Because flutter can quickly destroy components or your airplane, any time you detect flutter you must immediately cut the throttle and land the airplane! Check all servo grommets for deterioration (this may indicate which surface fluttered) and make sure all pushrod linkages are slop-free. If it fluttered once, it will probably flutter again under similar circumstances unless you can eliminate the slop or flexing in the linkages. Here are some things which can result in flutter: Excessive hinge gap; Not mounting control horns solidly; Sloppy fit of clevis pin in horn; elasticity present in flexible plastic pushrods; Side-play of pushrod in guide tube caused by tight bends; Sloppy fit of control rods in servo horns; Insufficient glue used when gluing in torque rods; Excessive flexing of aileron, caused by using too soft balsa; Excessive "play" or "backlash" in servo gears; and insecure servo mounting.

The Great Planes ElectriCub is a great-flying plane that flies smoothly and predictably. The ElectriCub does not, however, possess the self-recovery characteristics of a primary R/C trainer and should only be flown by experienced RC pilots.

Takeoff

Switch on the transmitter, then the receiver. Make sure the throttle stick is back (pulled towards you) before switching on the motor toggle switch. Takeoff on "low" rates if you have dual rates on your transmitter - especially if you are taking off into a crosswind. As the plane accelerates the tail will begin to lift and the plane will turn left (a characteristic of all taildraggers). Be ready for this and correct by applying sufficient right rudder to hold the plane straight down the runway. The left-turning tendency will go away as soon as the tail is up and the plane's speed increases. Be sure to allow the tail to come up. Do not hold the tail on the ground with up elevator, as the ElectriCub will become airborne prematurely and possibly stall. For all models it is good practice to gain as much speed as the length of the runway will permit before lifting off. When the plane has gained enough flying speed to safely lift off, gradually and smoothly apply up elevator and allow the model to climb at a shallow angle (do not yank the model off the ground into a steep climb!)

Flight

We recommend that you take it easy with your ElectriCub for the first several flights, gradually "getting acquainted" with this great model. Add and practice one maneuver at a time, learning how the ElectriCub behaves in each. Try to stay within a sensible and realistic scale-like flight envelope.

Sometime well before it's time to land, you should climb your ElectriCub to a safe altitude, reduce the throttle and check out the model's low speed characteristics. Do this a few times so you know what to expect upon landing and how the ElectriCub handles stalls.

Landing

With electric planes it's best to land with some battery power left. This will allow you to abort the landing and go around again if needed. When it is time to land, fly a normal landing pattern and approach. Keep a few clicks of power on until you are over the runway threshold. Then, reduce the power to low and the ElectriCub will naturally bleed off speed. Keep the nose down slightly, then level off just before touchdown. For your first few landings, plan to land slightly faster than stall speed and on the main wheels.

Have a ball! But always remember to think about your next move and plan each maneuver before you do it. Impulsively "jamming the sticks" without any thought is what gets most fliers in trouble rather than lack of flying skill. Happy Landings!

2-View

Use the 2-view or photocopy it and use the copy to design your trim scheme.

